



सत्यमेव जयते

HARMONISED GUIDELINES AND SPACE STANDARDS FOR BARRIER FREE BUILT ENVIRONMENT FOR PERSONS WITH DISABILITY AND ELDERLY PERSONS

FEBRUARY, 2016



Government of India
MINISTRY OF URBAN DEVELOPMENT



**HARMONISED GUIDELINES AND
SPACE STANDARDS FOR
BARRIER FREE BUILT ENVIRONMENT
FOR PERSONS WITH DISABILITY
AND ELDERLY PERSONS**

FEBRUARY, 2016

**Government of India
MINISTRY OF URBAN DEVELOPMENT**



सत्यमेव जयते

शहरी विकास मंत्री
भारत सरकार

MINISTER OF URBAN DEVELOPMENT
GOVERNMENT OF INDIA



MESSAGE

I am very happy that the ministry of Urban Development has brought out the '*Harmonised Guidelines and Space Standards for Barrier-Free Built Environment for persons with Disability and Elderly Persons*'.

India is a signatory to the *United Nation Convention on Rights of Persons with Disabilities, 2008*. We all need to work to realize human rights and development for persons with disabilities by removing barriers to their equal access. These guidelines have been framed to guide design of spaces to ensure equitable, easy access to persons with disabilities. Equitable access would translate into access to the physical environment, to transportation, to information and communications. Universal accessibility leads to increased opportunities for people with disabilities to access employment and to fully participate in the social, cultural, recreational, economic life of India.

I hope that these guidelines will be of great help to State Town and Country Planning Departments, Urban Development Authorities, Urban Local Bodies, and various other Institutions. The State Governments should proactively adopt these Guidelines as also recommended in the *Model Building Bye Laws, 2015* and include them in the preparation of plans for all urban areas. Ministry of Urban Development will always be keen to assist the State Governments in adoption of the Guidelines.

I congratulate the team members for framing the first document of its kind and for paving the way for a universally accessible and inclusive India.

(M. VENKAIAH NAIDU)



सत्यमेव जयते

राज्य मंत्री .शहरी विकास
भारत सरकार

MINISTER OF STATE FOR URBAN DEVELOPMENT
GOVERNMENT OF INDIA



MESSAGE

It gives me great pleasure to be a part of the launch of the '*Harmonised Guidelines and Space Standards for Barrier-Free Built Environment for persons with Disability and Elderly Persons*'.

These guidelines have been prepared by Ministry of Urban Development after extensive consultative process with various Central Government Ministries/ Agencies/ Bodies/ National Institutions/ State Governments. A new paradigm has been envisioned in these Guidelines and they provide a practical framework to facilitate design of spaces for persons with disability and cover a wide range of disability groups. Inclusive design of public and private spaces will ensure greater accessibility for persons with disabilities and empower them to participate actively in the society.

I congratulate the team members for formulating a pioneering document and strongly urge the State Governments to adopt the '*Harmonised Guidelines and Space Standards for Barrier-Free Built Environment for persons with Disability and Elderly Persons*', 2015. I am confident that it would lead the cities and towns of our country into a new era of accessible design and make them inclusiveliving places.

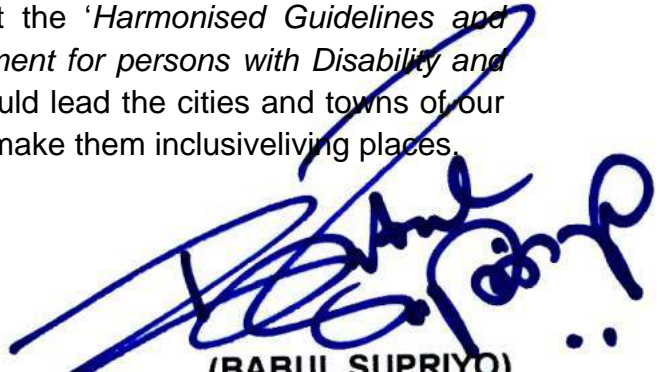

(BABUL SUPRIYO)



सत्यमेव जयते



PREFACE

Barriers to accessibility are obstacles that make it difficult for Person with Disabilities to move around in public places and access buildings. There are several barriers, both visible and invisible. Persons with disabilities face discrimination and barriers restrict them from participating in society on an equal basis in everyday life. In recent years, there has been a remarkable change in approach to ensure that persons with disabilities enjoy the same standards of equality, rights and dignity with the rest.

Harmonization of the three guidelines viz CPWD Guidelines 1998, Bureau of Indian Standards, National Building Code, 2005, Manual on Barrier Free Environment, O/o the Chief Commissioner for Persons with Disabilities, 2002 was undertaken by Ministry of Urban Development with the guidance of the Central Coordination Committee constituted under the provisions of the Persons with Disabilities (EOPRFP) Act 1995. Ministry of Urban Development, Government of India constituted a Committee that comprised of expert organizations that helped in preparing the present guidelines. Most of the recommended guidelines have been tested in developed countries and have proven to be effective.

Team of officers of the Ministry, Committee members, representatives from NGOs, IIT Roorkee, National Trust and Ministry of SJ & E and TCPO have worked painstakingly along with the various stakeholders across the country for formulating these Guidelines. The Guidelines are intended to be a reference for various aspects of planning by State Governments, Development Authorities, Planning Organizations and the Private Sector.

(M. PRASAD)

Secretary,

Ministry of Urban Development

Government of India

ACKNOWLEDGEMENT

In pursuance to the Person with Disabilities (Equal Opportunities, Protection of Rights and Full participation) Act, 1995 and to make built environment fully accessible, Ministry of Urban Development, Government of India took upon itself the task of preparation of the '*Harmonised Guidelines and Space Standards on Barrier Free Built Environment for Persons with Disability and Elderly Persons, 2015*'. These Guidelines intend to address the needs of persons with disabilities and elderly persons with a wide range of accessibility elements and standards and not limited to disabilities only, thus paving the way for universally accessible and inclusive India.

These Guidelines are the outcome of a participatory approach through widespread consultations with various Central Government Ministries, Civil Society Organisations, National Institutes and State Governments.

The exercise of formulation of these Guidelines was done under the overall leadership and guidance of Shri Madhusudan Prasad, Secretary, with support from Shri Durga Shanker Mishra, Additional Secretary, Shri Neeraj Mandloi, Joint Secretary and Shri Parmod Kumar, Director (UD) of the Ministry of Urban Development.

Mention also needs to be made for the tireless work put in by the officers of Town and Country Planning Organisation (TCPO) particularly, Shri Anil Kumar Rathore, Associate Architect under the supervision of Shri K.K. Joadder, Chief Planner and also the officers of Central Public Works Department (CPWD) including Shri R.K. Thathu, ADG, Architecture.

The Ministry of Urban Development acknowledges the work of Ms Anjlee Agarwal, Executive Director, *Samarthyam*, National Center for Accessible Environments, New Delhi, the member of the committee constituted by the Ministry who painstakingly updated and compiled the guidelines. The Ministry also acknowledges the contribution of other committee members from The Bureau of Indian Standards, Office of the Chief Commissioner for Persons with Disabilities, National Trust, Ministry of Social Justice and Empowerment, IIT Roorkee and *Svayam*. This compilation would not have been possible without the valuable inputs and suggestions provided by so many other participants and contributors. It is not possible to mention every ones name but their contribution is duly acknowledged.

BACKGROUND

The Government of India enacted the Persons with Disabilities (Equal Opportunities, Protection of Rights and Full Participation) (PWD) Act, 1995 and signed and ratified the UN Convention on the Rights of Persons with disabilities (CRPD) in 2008. Unlike the PWD Act, which defines disability in relation to medical conditions and degrees of impairment, the UNCRPD, sees disability as an interaction of impairments and barriers that hinder effective participation in society.

To realize accessibility as the rights issue for persons with disabilities as stipulated in the PWD Act and the UNCRPD, many agencies had laid down norms and standards for design of spaces for persons with disabilities, viz. Central Public Works Department (CPWD) Guidelines, National Building Code and Manual by the Chief Commissioner for Persons with Disabilities, Ministry of Social Justice & Empowerment (MSJE). Need was felt to compile the three guidelines into a comprehensive document for ready reference. This was noted during the 13th meeting of the Central Coordination Committee constituted by MSJE, held on 21st July, 2009 at the behest of the then Addl. Chief Planner, Town and Country Planning Organisation (TCPO).

With the intention to ensure that everyone, including the persons with disabilities and elderly should have equal access to all services and facilities in all public buildings, the Ministry of Urban Development (MoUD), Government of India constituted an Committee in 2009, vide O.M. dated 17th September 2009, comprising of experts from organizations which helped in harmonizing “Guidelines and Space Standards for Barrier Free Built Environment for Disabled and Elderly Persons, 1998” with the UNCRPD. The Committee was chaired by Joint Secretary (UD), Ministry of Urban Development, Director (UD) as Member Secretary and with members from Town & Country Planning Organisation (TCPO), Central Public Works Department (CPWD), Samarthyam National Centre for Accessible Environments, Bureau of Indian Standards, Svayam, Chief Commissioner for Persons with Disabilities, National Trust, IIT Roorkee and Ministry of Social Justice & Empowerment.

The Guidelines are the outcome of a participatory approach through widespread consultations with various Central Government Ministries/ Agencies/ Bodies/ National Institutions/ State Governments. Comments and suggestions of Civil Society Organizations in the field have been appropriately incorporated. The guideline has been published after technical vetting by TCPO and CPWD.

The Harmonised Guidelines are comprehensive guidelines inclusive of all provisions updated and harmonized to act as an *easy reference Practitioner’s Guide* for Barrier Free Designs with universal access, responding to the varying needs of the persons with disabilities. Some line drawings/ illustrations from Guidelines and Space

Standards for Barrier Free Built Environment for Disabled and Elderly Persons, 1998 are retained in this version.

The Guidelines build over the existing manuals, such as:

- Guidelines and Space Standards for Barrier Free Built Environment for Disabled and Elderly Persons, CPWD, 1998
- Manual on Barrier Free Environment, MSJE, 2002
- Annex D, National Building Code, Bureau of Indian Standards, 2005

These Guidelines explicitly covers universal accessibility standards and responds to the varying needs of all users including those with reduced mobility. The Guidelines are effective tool for the executing agencies, planners, designers, contractors, civic agencies, development authorities and urban local bodies, etc. to pave the way for inclusive and accessible built environment.

CONTENTS

CONTENTS	iii
LIST OF ILLUSTRATIONS.....	vi
ACRONYMS	ix
1 PREAMBLE	1
2 APPLICABILITY.....	3
3 ANTHROPOMETRICS	4
3.1 Mobility Devices and Space Allowances	4
3.2 Reach Range.....	7
3.3 Vision Zone.....	10
3.4 Heights and widths	10
4 CLASSIFICATION OF BUILDINGS	12
4.1 General categorisation of building typologies	12
4.2 Other categories	14
5 UNIVERSAL DESIGN ELEMENTS WITHIN BUILDING PREMISES	17
5.1 Site Planning.....	17
5.2 Space allowances	22
5.3 Floor surfaces.....	23
5.4 Approaches	23
5.5 Internal Corridors and Accessible Routes	25
5.6 Gratings.....	26
5.7 Doors.....	26
5.8 Windows	32
5.9 Handrail/ Grab Bars.....	32
5.10 Controls and Operating Mechanism	34
5.11 Seating Spaces.....	36
5.12 Other Facilities	37
5.13 Signage	39
5.14 Level Changes.....	39
5.15 Toilets.....	39
5.16 Parking	39
6 SIGNAGE	40
6.1 Signage Provisions.....	40

6.2	Types of Signages	41
6.3	Location.....	43
6.4	Universal Signage	43
7	LEVEL CHANGES.....	56
7.1	Kerb Ramps	56
7.2	Ramps.....	57
7.3	Stairs.....	60
7.4	Lifts.....	61
7.5	Wheelchair Stair-lift and Platform Lift	64
8	ACCESS TO TOILET FACILITY.....	65
8.1	General.....	65
8.2	Unisex Accessible Toilets (multi-use).....	65
8.3	Toilet Cubicle for Wheelchair Users.....	66
8.4	Toilet cubicle for Ambulatory Disabled.....	66
8.5	Toilet Doors.....	66
8.6	Water Closet	68
8.7	Water Closet Grab Bars.....	68
8.8	Washroom Accessories.....	69
8.9	Urinals	69
8.10	Signage of accessible toilets.....	70
8.11	Shower Cubicles	71
8.12	Public toilets.....	72
9	FIRE EVACUATION NEEDS	74
9.1	Alarm Panels	74
9.2	Alerting Systems.....	74
9.3	Evacuation Plans	74
9.4	Emergency Evacuation Routes.....	74
9.5	Provision of Refuge Areas	75
10	ALIGHTING AND BOARDING AREAS	77
10.1	Car Parks	77
10.2	Taxi/Auto Rickshaw Stands	78
10.3	Bus Stops	80
10.4	Railway Stations and Airports	81
10.5	Piers and Jetties	84

11	TRANSPORT AND ROAD PLANNING	85
11.1	Sidewalks / Footpaths	85
11.2	Kerb Ramps at Walkways and Pedestrian Crossings.....	85
11.3	Road Intersections	85
11.4	Median Refuge/Islands	86
11.5	Traffic signals	86
11.6	Subways and Foot Over Bridges	86
11.7	Public Transport.....	88
12	ADAPTED HOUSING.....	95
12.1	Exterior.....	95
12.2	Interior	95
12.3	Bedroom	96
12.4	Living Room.....	97
12.5	Washroom.....	97
12.6	Kitchen	97
13	ACCESS AUDIT CHECKLIST.....	99
	INTERNATIONAL PRACTICES IN BARRIER FREE STANDARDS	cx
	BIBLIOGRAPHY	cxv
	GLOSSARY	cxvi

LIST OF ILLUSTRATIONS

Figure 3-1: Structure of wheelchair and name of each part (standard type).....	4
Figure 3-2: Dimensions of manual wheel chair in usable and folded condition	5
Figure 3-3: Knee clearance.....	5
Figure 3-5: Turning radius.....	6
Figure 3-4: Clear floor space	6
Figure 3-6: Space requirement for crutch user	6
Figure 3-7: Radial range and object detection by the visually impaired.....	7
Figure 3-8: Range of reach of wheel chair user	7
Figure 3-9: Forward and lower reach of wheel chair user.....	8
Figure 3-10: Side upper reach and side lower reach	8
Figure 3-11: Forward and side reach over obstruction	9
Figure 3-12: Common reach zone	9
Figure 3-13: Field of Vision	10
Figure 3-14: Vision zone	10
Figure: 4-1: Wheelchair sitting in a hall.....	14
Figure 4-2: Wheel chair, aisle and reach height	15
Figure 5-2: Warning blocks	18
Figure 5-4: Configuration and layout of tactile pavers: guiding and warning	19
Figure 5-5: Bollards with spacing for wheelchair users/prams.....	20
Figure 5-6: Protruding obstacles placed in a niche	21
Figure 5-7: Clearance from protruding obstacles.....	21
Figure 5-8: Placement of obstacles outside path of travel	21
Figure 5-9: Minimum width of a clear walkway	22
Figure 5-10: Door opening	24
Figure 5-12: Wheelchair Castor Width.....	26
Figure 5-11: Grating Width.....	26
Figure 5-13: Preferred design of gratings	26
Figure 5-14: Installation Guide.....	26
Figure 5-15: Clear door width	27
Figure 5-16: Maneuvering space needed for wheelchair users to approach doors.....	28
Figure 5-17: Position taken by wheelchair when negotiating door in passageway	28
Figure 5-18: Space between two doors	29
Figure 5-19: Space for wheelchair in 90 ⁰ turn.....	29
Figure 5-21: Maneuvering space needed for approach doors	29
Figure 5-20: Maneuvering space needed for wheelchair users to approach doors	29
Figure 5-22: Door hardware location	30
Figure 5-23: Preferred door handles.....	30
Figure 5-24: Glass door markings.....	31
Figure 5-25: Recommended visibility zone	31
Figure 5-26: Standards for accessible window	32
Figure 5-27: Handrail with Braille Information Panel.....	33
Figure 5-28: Handrail standards	33
Figure 5-29: Space clearance for control operations	34
Figure 5-30: Location of electrical sockets, control, etc.	35
Figure 5-32: Long handle tap.....	36
Figure 5-31: Lever handle tap.....	36

Figure 5-33: Clear floor space for wheelchair	36
Figure 5-34: Counter tops/table height	36
Figure 5-35: Drinking water fountain.....	37
Figure 5-38: Telephone height.....	38
Figure 5-37: Space allowance for telephone counter	38
Figure 5-38: Accessible public telephone	38
Figure 6-1: Directional signage for ramp.....	41
Figure 6-2: Directional signage for rooms.....	41
Figure 6-3: Destination signage.....	42
Figure 6-4: Information signage.....	42
Figure 6-5: Mandatory signs	42
Figure 6-6: Instructive signs.....	42
Figure 6-10: Signage with embossed letters and Pictogram	43
Figure 6-8: Signage- Typeface and Style	45
Figure 6-7: Preferred colour contrast.....	45
Figure 6-9: Signage in upper and lower case	46
Figure 6-11: Spacing between lines.....	47
Figure 6-12: Character Proportion	47
Figure 6-13: Character Height	47
Figure 6-14: Access symbols.....	47
Figure 6-15: Information signage.....	47
Figure 6-16: Preferred location of signages.....	48
Figure 6-17: Height and placement of signages	49
Figure 6-18: Viewing distance for signages	49
Figure 6-20: Braille locator -tactile signs.....	51
Figure 6-19: Embossed letters – tactile signs	51
Figure 6-21: Braille specifications	52
Figure 6-23: Tactile and audio map	52
Figure 6-22: Tactile map	52
Figure 6-24: Speaker and buttons in talking signs.....	53
Figure 6-25: Talking signs.....	53
Figure 6-26: Assisted Access	53
Figure 6-27: International Symbol of Accessibility	53
Figure 6-28: Signage for accessible Access.....	54
Figure 6-29: Signage for Accessible Facilities	54
Figure 6-30: Signage for Persons with Vision Impairment.....	54
Figure 6-31: Pictograms for Accessible Facilities	55
Figure 7-1: Kerb ramp detail	56
Figure 7-3: Kerb extension at street intersection	56
Figure 7-2: Typical kerb ramp requirements	56
Figure 7-4: Kerb ramp detail	57
Figure 7-5: L-shape ramp with landing	59
Figure 7-6: Typical handrail extensions	59
Figure 7-7: Continuous and extended handrail.....	60
Figure 7-8: Placement of warning blocks for steps	60
Figure 7-9: Warning blocks at landings.....	60
Figure 7-10: Colour contrast for step edges	61
Figure 7-11: Guard rail under soffit	61

Figure 7-12: Way finding signage for lift location	61
Figure 7-13: Size of lift	62
Figure 7-14: Placement of lift accessories	62
Figure 7-16: Specifications of lift controls	63
Figure 7-15: Layout of lift control panel.....	63
Figure 7-17: Stair lift.....	64
Figure 7-18: Platform chair lift and platform lift	64
Figure 8-1: Wheelchair maneuvering space in toilet.....	65
Figure 8-2: Layout plan of unisex accessible toilet	66
Figure 8-3: Suggested Plan WC Compartment for the Ambulant Disabled	67
Figure 8-4: WC Compartment for the Ambulant Disabled.....	67
Figure 8-6: Grab bars specifications	69
Figure 8-5: Washbasin specifications	69
Figure 8-7: Urinal with chest support grab bar	69
Figure 8-8: Signage for Unisex toilet, gents and ladies toilet.....	70
Figure 8-9: Shower Cubicle	70
Figure 8-10: Placement of signage	70
Figure 8-11: Roll in shower cubicle.....	71
Figure 8-12: Placement of shower accessories	72
Figure 8-13: Unisex public toilet.....	73
Figure 10-1: Accessible parking standards	78
Figure 10-2: General plan of parking	79
Figure 10-3: Layout for accessible taxi/car boarding	79
Figure 10-4: Bus stop design	81
Figure 10-5: Counter tops	82
Figure 10-6: Warning blocks on platform edges	83
Figure 10-7: Level boarding in Delhi metro Rail Coach	84
Figure 10-8: Warning strip on platform	84
Figure 11-1: Kerb ramp placements at turnings.....	85
Figure 11-2: Median refuge/island	86
Figure 11-3: Pedestrian foot over ridge with ramp and steps	87
Figure 11-4: Pedestrian foot over bridge with ramp and lift facilities	87
Figure 11-5: Lift access to subway crossing	88
Figure 11-6: Lift access to Foot Over Bridge	88
Figure 11-7: Low floor bus boarding from road level and bus stand platform	89
Figure 11-8: Wheelchair space in bus	89
Figure 11-9: Accessible taxi.....	90
Figure 11-10: Information boards on platforms/concourse	90
Figure 11-11: Rail/ Metro door signage	91
Figure 11-12: Retrofitting of ramp for sub-urban rail.....	91
Figure 11-13: Reserved space for wheelchair user	92
Figure 11-14: Accessible ferry	93
Figure 12-1: Storage space	97
Figure 12-2: Space around bed	97
Figure 12-3: Shelves and cupboards.....	98
Figure 12-4: Kitchen shelves and cabinets	98

ACRONYMS

BRTS	Bus Rapid Transit System
DTC	Delhi Transport Corporation
FOB	Foot Over Bridges
MCD	Municipal Corporation of Delhi
MoUD	Ministry of Urban Development
MRTS	Mass Rapid Transit System
MSJ&E	Ministry of Social Justice & Empowerment
NDMC	New Delhi Municipal Council
NGO	Non-Government Organization
PRM	Persons with Reduced Mobility
PWD	Public Works Department
PwDs	Persons with Disabilities
ROW	Right of Way
TRB	Transport Research Board
ULB	Urban Local Body
UNCRPD	United Nations Convention on Rights of Persons with Disabilities
WwD(s)	Woman / en with Disability / ies

1 PREAMBLE

The city provides an abundance of opportunities and experiences for many people in India, free of limitations imposed of the built environment. The built environment, however, imposes numerous obstacles for Persons with Disabilities in India that limit their ability to move about freely and safely without concern.

United Nation Convention on Rights of Persons with Disabilities(UNCRPD, 2008)

CRPD came into force in India in May 2008. Unlike the Person with Disability Act, 1995, which defines disability in relation to medical conditions and degrees of impairment, the UN Convention, sees disability as an interaction of impairments and barriers that hinder effective participation in a society.

The Government of India (GOI) has signed and ratified the Convention but to comprehend all dimensions of the Convention, stakeholders need to understand and think deeply about the rights of Persons with Disabilities and how to operationalise them.

Article 9 of UNCRPD: Accessibility

To enable Persons with Disabilities to live independently and participate fully in all aspects of life, States shall take appropriate measures to ensure access to Persons with Disabilities, on an equal basis with others, to the physical environment, to transportation, to information and communications, including information and communications technologies and systems, and to other facilities and services open or provided to the public, both in urban and in rural areas. These measures, which shall include the identification and elimination of obstacles and barriers to accessibility, shall apply to, inter alia:

- a. Buildings, roads, transportation and other indoor and outdoor facilities, including schools, housing, medical facilities and workplaces;
- b. Information, communications and other services, including electronic services and emergency services.

The benefits of accessibility are significant. Aside from responding to the needs of Persons with Disabilities, increasing accessibility leads to increased opportunities for Persons with Disabilities to access employment and to fully participate in the social, cultural, recreational, economic life of India. Moreover, to compete nationally and internationally, a barrier-free city can increase tourism and provide a competitive advantage.

During the design, planning and construction of accessible spaces and buildings a wide range of opportunities exist not only to optimize independent access to Persons with Disabilities but also to improve access for all. The major objective of the Barrier Free Design Guidelines, which are based on Universal Design principles, is to guide City authorities when considering or developing public projects. The guidelines will serve as a reference for developing future policies, guidelines, standards and other initiatives that serve the needs of Persons with Disabilities. The guidelines are in keeping with the Official Plan, which states that "A key city-building principle is that public buildings, parks and open spaces should be open and accessible to all members of the public including people with disabilities."

The Barrier Free Design Guidelines have been made considering:

- a wide variety of internal and external building elements should be universally accessible to comply with universal design principles;
- retrofitting of old buildings and new buildings should ensure full accessibility from planning stage itself;
- an equivalent level of safety for everyone, including modes of ingress/ egress/ communication in an emergency;
- the need to emphasize dignity and independence of Persons with Disabilities, (providing features that will allow people to function smoothly in their day-to-day activities); and
- to be non-institutional and successfully integrated with a building's function, form and architectural quality.

2 APPLICABILITY

The Person with Disability Act, 1995 mandates that persons with disabilities be provided with equal opportunities and protects their rights to full participation. This, therefore, requires that spaces be designed to suit the needs of all persons with disabilities. Also, Model Building Bye Laws, 2015 mandate that barrier free environments are maintained to ensure inclusive cities and universal designs.

These guidelines will apply to all public buildings in India, including the buildings where access is open to general public.

The guidelines and specifications deal with access to, movement within and around buildings, by Persons with Disabilities and elderly persons.

The intent is to make buildings and facilities accessible to and usable by all people including those living with disabilities and may include those with inability to walk or difficulty in walking, reliance on walking/ mobility aids, blindness and visual impairments, speech and hearing impairments, limited-coordination of motor movements, reaching and manipulation, lack of stamina, difficulty in interpretation and reacting to sensory information and extremities of physical size.

3 ANTHROPOMETRICS

This chapter contains dimensions that can be used for guidance when designing facilities and equipment to be used by Persons with Disabilities. Adequate space should be allocated for persons using mobility devices, e.g. wheelchairs, crutches and walkers, white cane etc. as well as those walking with the assistance of other persons (Figure3-1, 3-2 and 3-3).

3.1 Mobility Devices and Space Allowances

Standard wheelchair parts are given in Figure3-1.

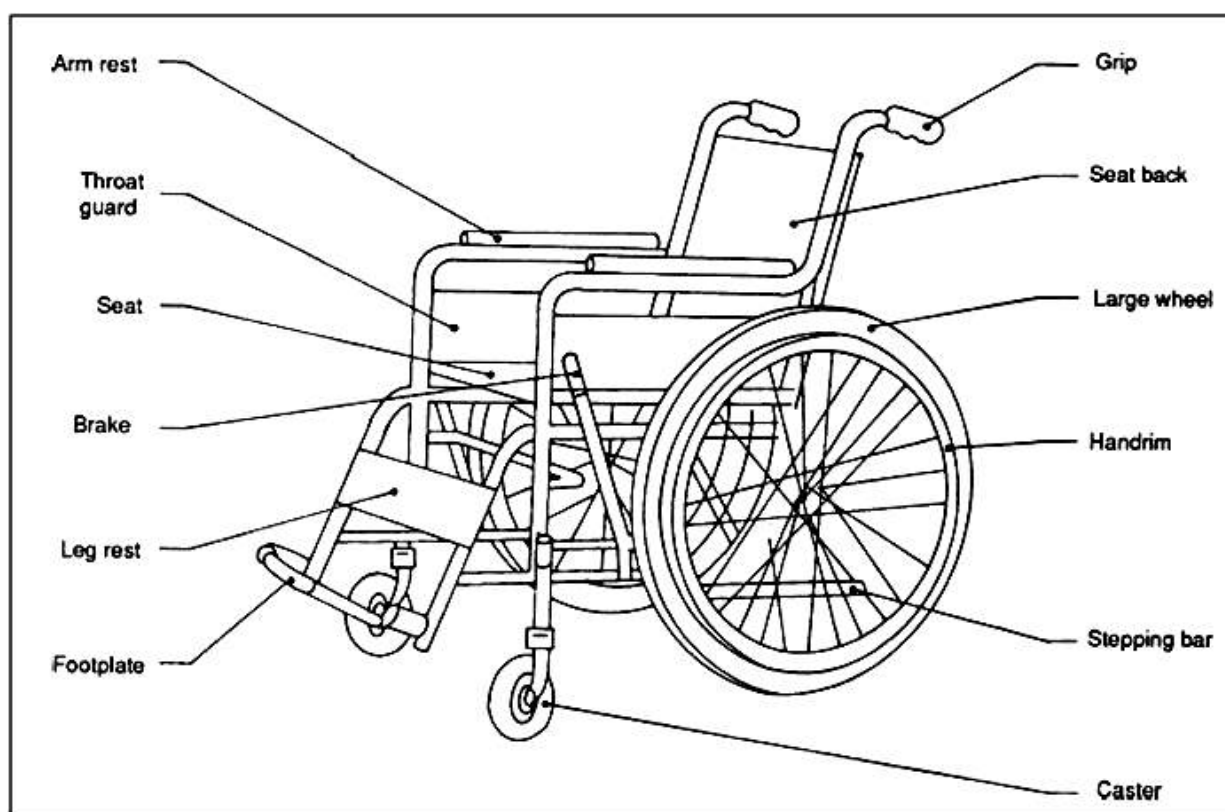

Figure 3-1: Structure of wheelchair and name of each part (standard type)

3.1.1 Wheel chair

Some of the typical dimensions of a standard wheelchair are extremely important and helps to get standards for space allowance, reach range, etc. of a wheelchair user. Electric wheelchairs may be of a larger dimension, much heavier and do not have the same maneuverability/capability as manual wheelchairs.

Manual wheelchairs dimensions are as follows: (Figure 3-2)

- Length: 1000 - 1200 mm
- Width: 650 - 720 mm
- Height: 910-950mm
- Wheelchair footrest: 350 mm (deep)

- Wheelchair castor width: 12 mm
- Seat ht.: 480mm
- Arm rest ht.: 760mm
- Lap ht.: 675 mm

When the wheelchair is folded (Figure 3-2)

- Width: 300 mm
- Height of armrest: 760 mm

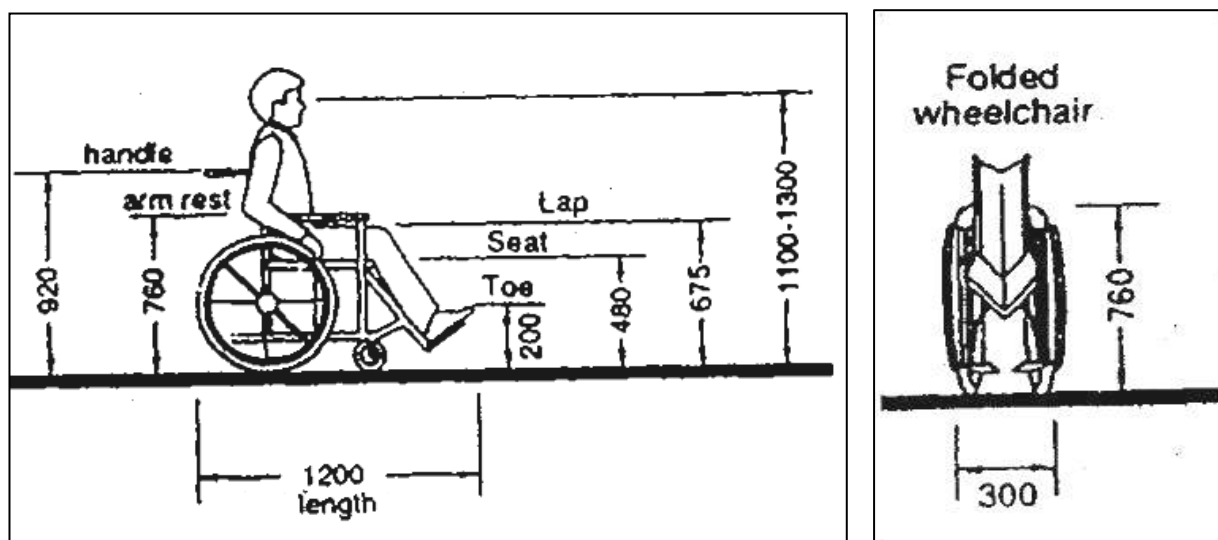

Figure 3-2: Dimensions of manual wheel chair in usable and folded condition

A wheelchair has a footplate and leg rest attached in front of the seat. (The footplate extends about 350 mm in front of the knee). The footplate may prevent a wheelchair user from getting close enough to an object. Hence, at least 350 mm deep and 700 mm high space under a counter, stand, etc. should be given.(Figure 3-3)

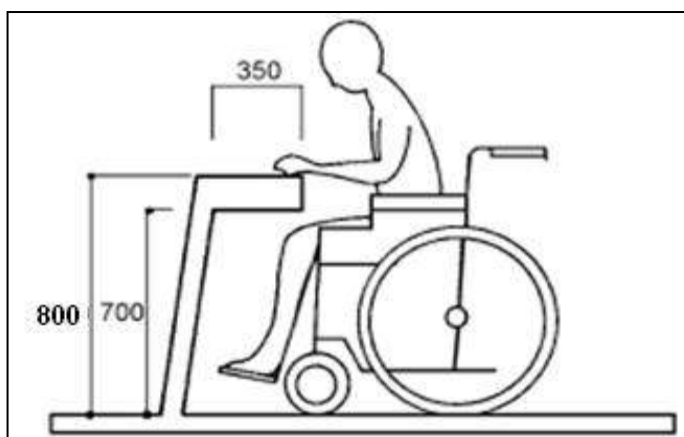

Figure 3-3: Knee clearance

3.1.1.1 Wheelchair user

The minimum clear floor or ground area required accommodating a single, stationary wheel chair and occupant is 900 mm x 1200 mm (Figure3-4).

- Width: 900mm
- Length: 1200mm

3.1.1.2 Circulation dimensions

The minimum clear floor ground area for a wheelchair to turn is 1500 mm whereas it may be ideal to provide 2000 mm (Figure 3-5).

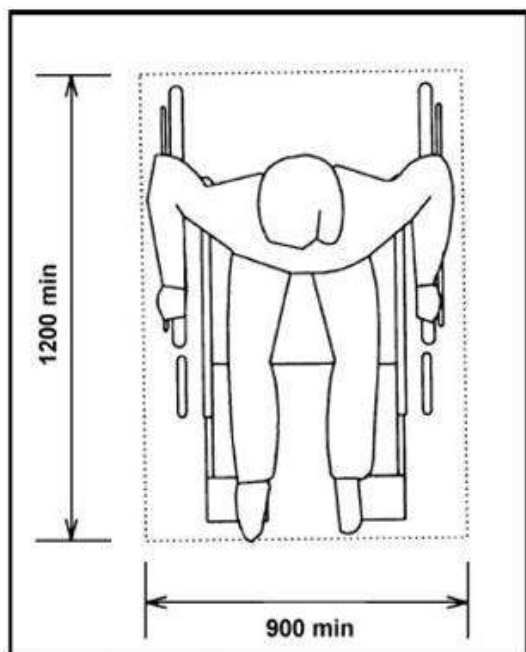

Figure 3-5: Clear floor space

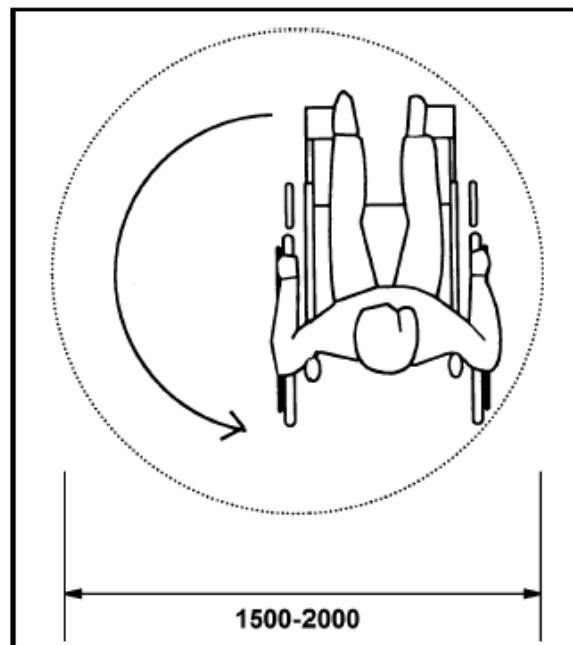

Figure 3-4: Turning radius

3.1.2 Space Allowance for crutch user

Although people who use walking aids can manoeuvre through door openings of 900 mm clear width, they need wider passageways 920mm for comfortable gait (Figure 3-6).

Crutch tips, often extend down out at a wide angle, are a hazard in narrow passageways where they might not be seen by other pedestrians.

- Width: 920mm
- With no obstruction up to 300mm height

3.1.3 Space allowance for white cane users

- Protruding objects, such as directional signs, tree branches, wires, guy ropes, public telephone booths, benches and ornamental fixtures should be installed with consideration of the range of a person with vision impairment white cane.

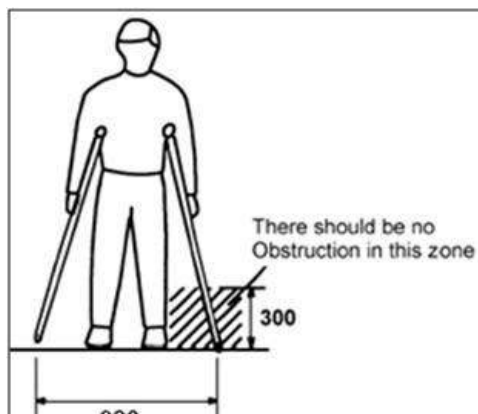

Figure 3-6: Space requirement for crutch user

- A barrier to warn blind or visually impaired persons should be provided under stairways or escalators.
- Walkways, halls, corridors, passageways, aisles, or other circulation spaces should have clear headroom to minimize the risk of accidents.
- The radial range of the white cane is a band 900 mm wide. (Figure 3-7).
- Any obstacle above 600 mm cannot be detected by the white cane. If there are projections above this height then the projections have to be reflected at the floor level in terms of level or textural differences. (Figure 3-7).

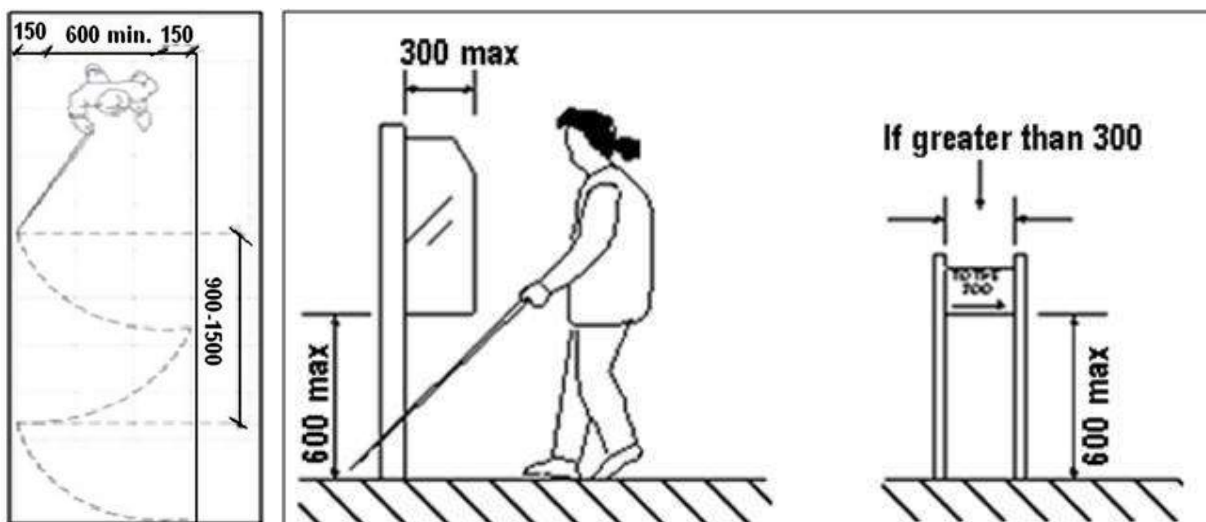

Figure 3-7: Radial range and object detection by the visually impaired

3.2 Reach Range

- A wheelchair user's movement pivots around his or her shoulders (Figure 3-8).
- The range of reach (forward and side; with or without obstruction) of a wheelchair user should be taken into consideration.

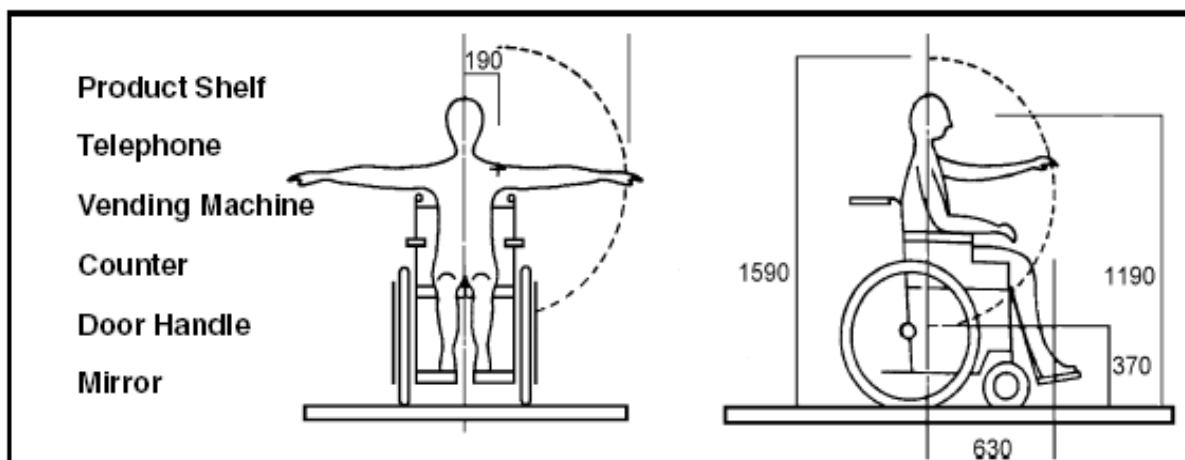

Figure 3-8: Range of reach of wheel chair user

3.2.1 Reachwithout obstruction

The maximum forward reach is 1200mm from the floor and the minimum forward reach is 380 mm from the floor (Figure 3-9, 3-10).

- Max. forward upper reach:1200 mm
- Max. forward lower reach: 380 mm

The maximum side reach without obstruction is 1300mm from the floor and the minimum side reach is 250mm as shown in the figure below.

- Max. side reach (upper level): 1300 mm
- Max. side reach (lower level): 250 mm

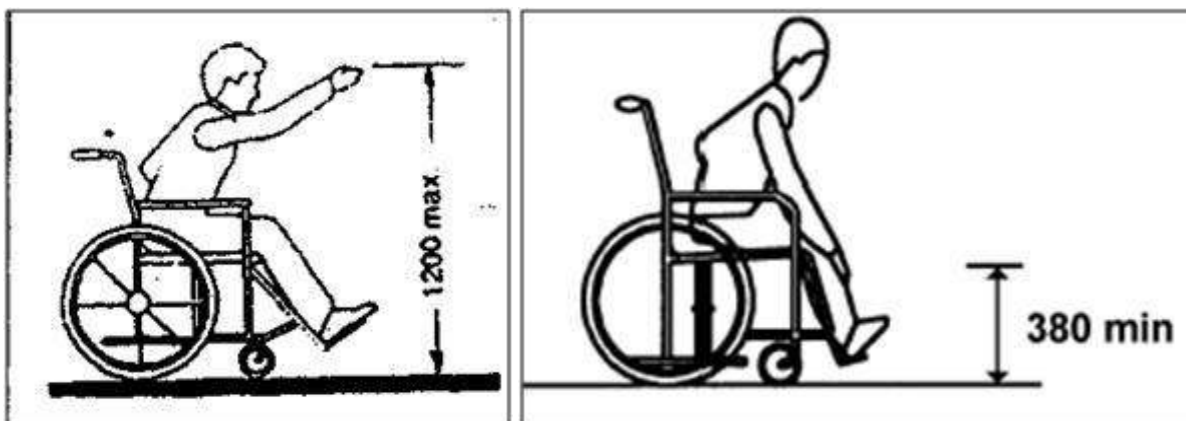

Figure 3-9: Forward and lower reach of wheel chair user

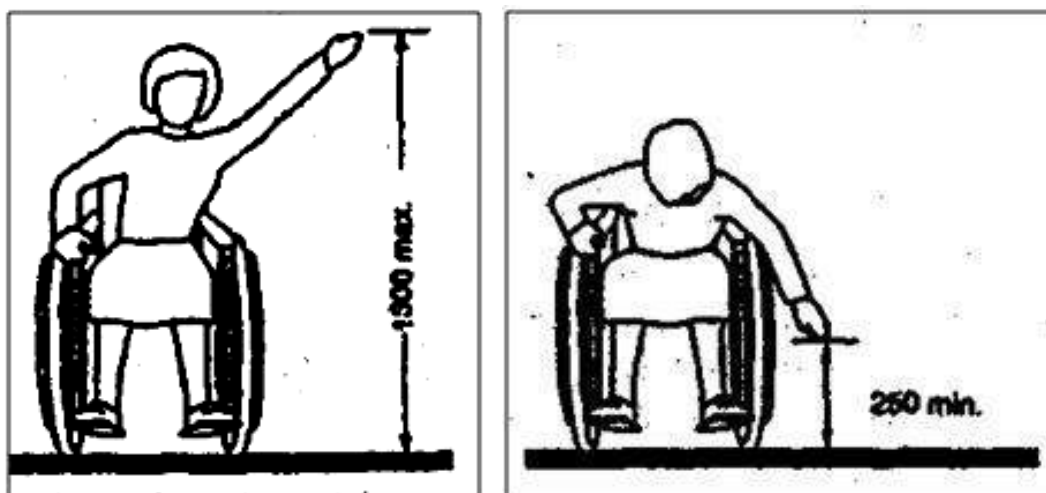

Figure 3-10: Side upper reach and side lower reach

3.2.2 Reach over obstruction (Max. 500mm deep)

The maximum forward reach over an obstruction is 1000mm from the floor (Figure 3-11).

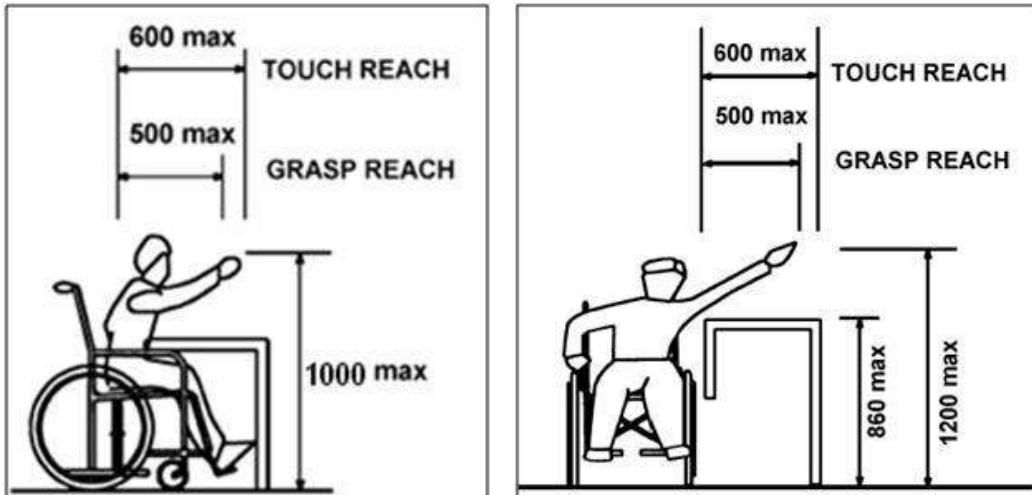

Figure 3-11: Forward and side reach over obstruction

The maximum side-reach over an obstruction 860mm high x 500mm deep is 1200mm (Figure 3-12).

- Max. Side reach over obstruction (upper) – 1200 mm from floor level
- Max. Side reach over obstruction (lower) – 500 mm

3.2.3 Common reach zone

- The comfortable reach zone when seated on a wheelchair is between 900 mm and 1200 mm.
- The maximum reach zone is between 1200 mm and 1400 mm. (Figure 3-12)

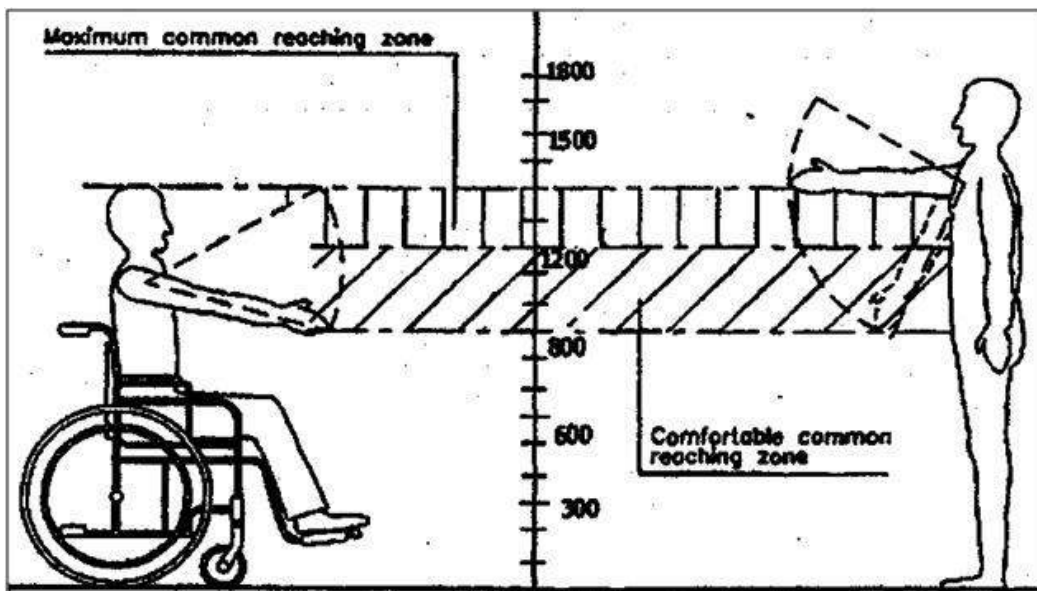

Figure 3-12: Common reach zone

3.3 Vision Zone

Different fields of vision are given in Figure 3-13. All signage should be designed based upon these dimensions.

- Vision zone: 900 - 1800 mm

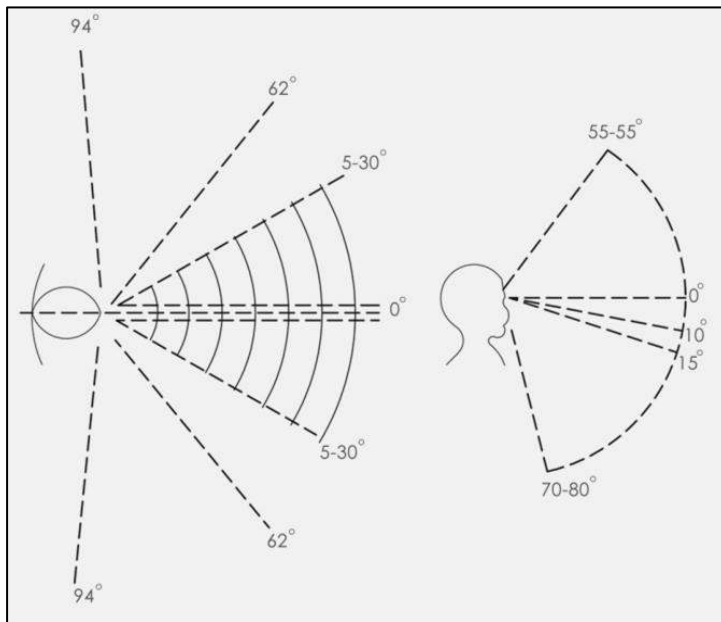

Figure 3-13: Field of Vision

The smallest letter should not be less than 15 mm. Map and information panels along pathways should be placed at a height between 900 mm and 1800 mm (Figure 3-14).

3.4 Heights and widths

3.4.1 Wheelchair Users

- The average height of a person seated on a wheelchair is generally less than 1200mm.

3.4.2 Standing Person

- The average height of a standing person is generally less than 2000mm.

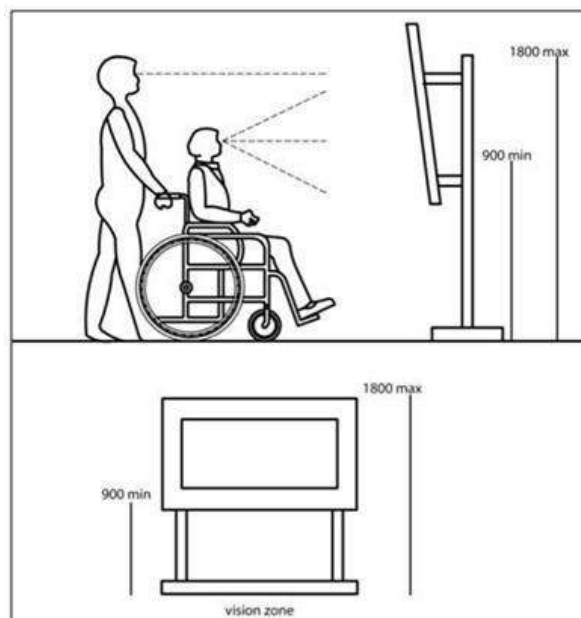

Figure 3-14: Vision zone

3.4.3 Height of controls

- Height of controls from floor level : 400 – 1200mm
- Height for switches (power) : 400 - 500 mm
- Height for switches (light) : 900 –1200 mm

- Height of doors handles : 900 – 1000 mm
- Opening controls for windows : 900 – 1000 mm
- Space required under the counter for wheelchair footrest: 350mm deep

3.4.4 Entrance/ exit door

- Min. width of entrance/ exit door : 900 mm
- Min. front approach doorways space : 600 mm
- Min. Latch approach doorways space : 1250mm

4 CLASSIFICATION OF BUILDINGS

All public buildings have to comply with accessibility requirements for Persons with Disabilities including government institutions, office buildings, residential buildings, commercial buildings, health facilities, restaurants, recreational and sports facilities, religious buildings and all other building types used by the general public.

For accessible buildings, at least one entrance per facility should be accessible to a wheelchair user. For new buildings, the accessible entrance(s) should be the main entrance(s), and not side or back entry, intended for use by the public.

Wherever waiting areas, coffee shops, display areas, merchandising departments, service areas, ticket counters, refreshment stands, etc. are provided for public use, these facilities should be accessible to all Persons with Disabilities and not just wheelchair users only.

In all buildings at least one unisex accessible washroom/toilet should be provided. In multi-level buildings all floors should have one such facility near the general washrooms.

4.1 General categorisation of building typologies

Category 1: Residential

In new apartment buildings construction for rent or sale, access elements for Persons with Disabilities should be provided. In old constructions, modification of entry & exit, kitchens, washrooms, rooms, etc. should be carried out as per Chapter 5.

Category 2: Commercial (Retail Shopping Zone, General Business)

In large multi-storey department stores and supermarkets, accessible elevators should be installed to provide access to lower and/or upper levels for the benefit of wheelchair users and people with mobility problems. Merchandise display areas in accessible shops should be as conveniently located as possible to a wheelchair user. Angled mirrors can be placed above high shelves for visibility. Braille list, menus, and signage should be provided for persons with visual impairments. All signage should be in contrast colour and large font. In clothes shops, at least one changing room should have door with 900mm clearance and allow for a full 360⁰ turn of a wheelchair. All modifications should be carried out as per chapter 5.

Category 3: Manufacturing

- Service and Light Industry
- Special Industrial Zone
- Hazardous, Noxious and Chemical

Arrangements for employees with disabilities are directly related to the type of work they perform. Arrangements for Persons with Disabilities need not be considered in heavy manufacturing factories.

Arrangements for all Persons with Disabilities should be incorporated into the design of new light manufacturing factories where disabled people may be employed.

Category 4: Building open to public (public & private)

- Government/ Semi Government/ Public Offices
- Education & research, Medical and Health
- Social Cultural and Religious
- Utilities and Services
- Cremation and burial grounds

New office buildings should be fully accessible as per chapter 5.

New low-rise (single/ double storey) office blocks with no elevators should have accessible ground level public dealing office/ counters.

For small office buildings where the floor area limits the provision of accessible washrooms / toilets on each floor, one unisex accessible washroom (Section 8.2) on ground level shall be provided to serve the entire building. The unisex accessible washroom should be located adjacent to an accessible elevator.

Where an office building is subdivided among various tenants, unisex accessible washroom (Section 8.2) should be provided on each floor.

Category 5: Recreational

- Play ground/ stadium/ sports complex
- Parks & Gardens- public open spaces
- Special recreational zone – restricted open spaces
- Multi-use open spaces

Category 6: Transportation & Communication

- Roads
- Railways
- Airports
- Seaports and Dockyards
- Bus Depots / Truck Terminals & Freight complexes

Category 7: Agricultural and Water bodies

- Agriculture
- Forest
- Poultry & dairy Farming
- Rural Settlements
- Brick Kiln and extractive areas
- Water bodies

Category 8: Special Areas

- Old built up (core) area
- Heritage and Conservation area
- Scenic value area

4.2 Other categories

i. Assembly Halls

Under this category fall movie-theatres, lecture halls, spectator seating in sports centres, and other assembly halls with fixed seating. The number of spaces designated for wheelchair users in a seating area can be estimated according to Table 4-1:

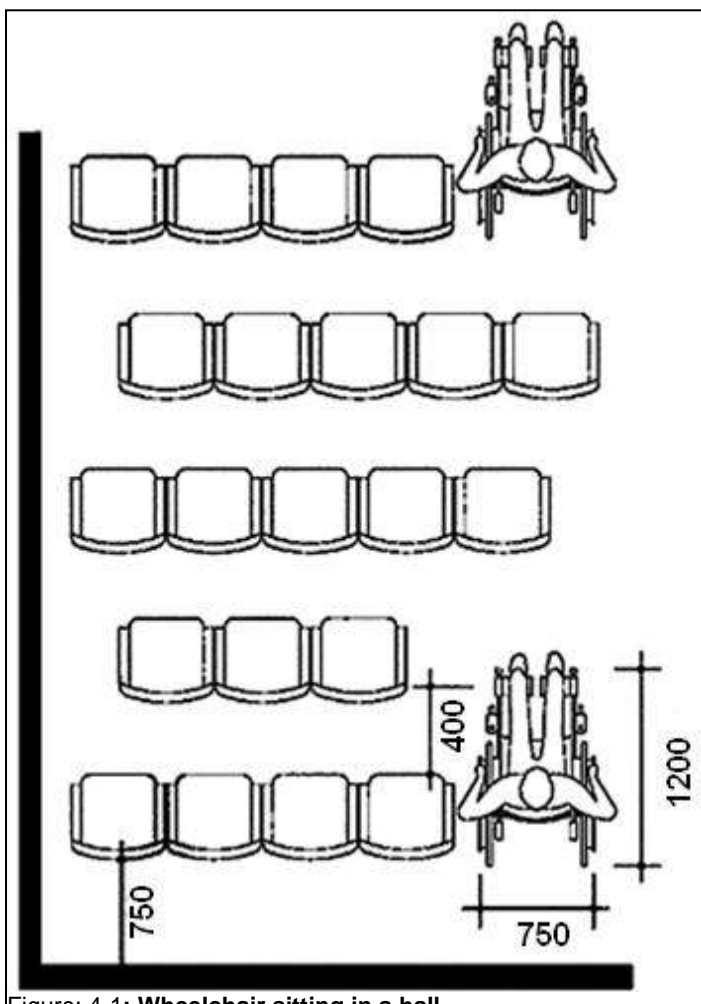

Figure: 4-1: Wheelchair sitting in a hall

Table 4-1: Seating for wheelchair users in Halls/theatre/stadiums

Number of seats in a seating area	Number of required spaces for wheelchair users
up to 600	6 i.e. 1/100
up to 1000	6 + 2
over 1000	8+1 for each additional increment of 1000 seats

Some seats with removable or flip-up armrests should be provided at row ends to accommodate a wheelchair user or a person with limited ambulatory mobility. A level floor area for wheelchair users should be placed at row ends and should be scattered on different levels so as to have a variety of seating and viewing locations (Figure 4-1).

ii. Cafeterias and Restaurants

- New restaurants or parts of new restaurants and eating spaces should be accessible and Persons with Disabilities and elderly should use facilities and services.
- Old buildings should be retrofitted as per the standards given in chapter 5.
- In self-service restaurants, tray slides and counters should be mounted at 800mm from the floor for wheel chair users. Food shelves should be mounted at a maximum height of 1200 mm and aisle space of minimum 900mm should be provided (Figure 4-2).
- Cantilevered tables or tables with straight legs at each corner are preferable to central pedestals that might restrict wheelchair access.
- Stools and high tables are not suitable for wheelchair users. Low tables should be provided as well.

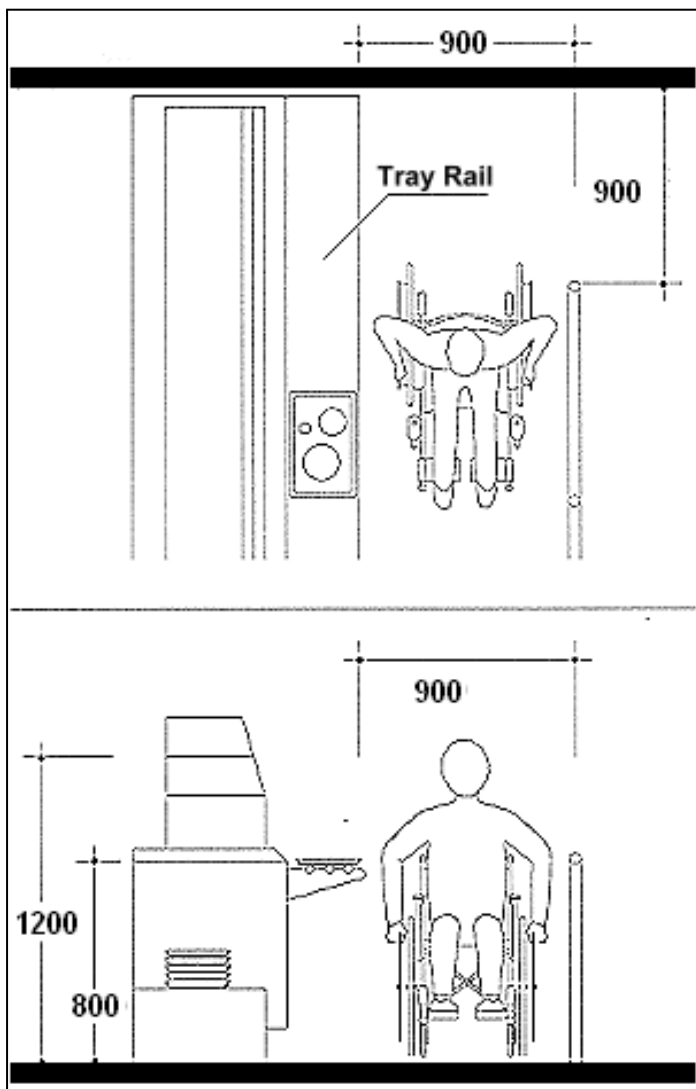

Figure 4-2: Wheel chair, aisle and reach height

iii. Hotels

- At least two rooms per new hotel or motel should be accessible to a wheelchair user (Chapter 12).
- Bathrooms connected to these rooms have to be fully equipped (Section 8.2 and 8.12). Rooms designated for wheelchair users should, where possible, should be placed at ground level so as to have a direct means of escape in case of fire. Refer Chapter 5 for accessible elements and Chapter 9 for safe evacuation standards.

iv. Hospitals and Health Facilities

- All facilities and services should be accessible as per Chapter 5.

v. Educational buildings

- All teaching, administrative and common areas should be accessible to Persons with Disabilities.

- Arrangements for wheelchair users by means of ramps/ lift should be made for stepped lecture halls or auditoriums.
- At least one accessible unisex washroom should be provided on each floor including student dormitories and residential accommodations.
- All recreational facilities should be usable by Persons with Disabilities.
- Colleges for physical education, police or military training and other activities requiring full physical abilities should also be made accessible for administrative staff members, employees and visitors with disabilities.

vi. Libraries

- All open book stacks should be accessible.
- All library facilities and equipment should be accessible.
- A special room should be provided for people with hearing and vision impairment who need assistance while reading.

vii. Sports buildings

- Sports halls should be fully accessible as per Chapter 5.
- At least one shower room (Section 8.12), one washroom (Section 8.2) and one changing room per facility should be accessible to a wheelchair user.
- Spectators' seating areas should be provided for wheelchair users as specified (Figure4-1 and Table 4-1).

viii. Public transit buildings

All public areas used by passengers such as banks, shops, waiting areas, customs areas, baggage halls, booking halls, waiting areas, inquiry offices, etc. should be accessible.

ix. Industrial buildings

The highest degree of accessibility to all people should be provided to the extent possible in accordance with the requirements mentioned in Chapter 5.

x. Historic buildings

It is possible to adapt / suit the requirements of disabled people without affecting the historical character. The challenge is to find alternative solutions or other innovative methods that do not conflict with preservation requirements. The character of a historical building should be preserved and accessibility should be provided for Persons with Disabilities and elderly.

5 UNIVERSAL DESIGN ELEMENTS WITHIN BUILDING PREMISES

5.1 Site Planning

Each building and its site should be planned and designed as an integral unit from the very beginning of the design process.

5.1.1 Walks and paths

- Walks should be smooth, hard and have levelled surface suitable for walking and wheeling. Irregular surfaces as cobble stones coarsely exposed aggregate concrete, bricks etc. often cause bumpy rides and should be avoided
- Minimum walk way width for two way traffic should be 1800mm. However, in exceptional cases (such as around trees/poles etc.); the width could be 1500mm.
- The walkway should not have a gradient exceeding 1:20. It also refers to cross slope.
- When walks exceed 60 meter in length it is desirable to provide rest area adjacent to the walk at convenient intervals of 30 meter for bench/ resting seats. For comfort, seat height should be between 450 mm-500 mm, have a backrest and hand rests at 700 mm height.
- Texture change should be provided for persons with vision impairment in walkways adjacent to seating by means of warning tactile pavers.
- Avoid gratings and manholes in walks.

5.1.2 Levels, grooves and gratings

Passing over different levels and grooves, vertical level changes up to 6 mm may not need edge treatment. Changes in level between 6 mm and 12 mm should be leveled off with a slope no greater than 1:2.

- To prevent a wheelchair from getting its casters caught in a drainage ditch or grating cover, install grating with a narrow slots not more than 10mm wide, perpendicular to the direction of movement.
- Grating should be flushed with finished ground level.
- Treat the grating with a non-slip finish.

5.1.3 Tactile pavers: guiding & warning blocks

5.1.3.1 Tactile guiding blocks (Line-type)

This block indicates a correct path/route to follow for a person with visual impairment (Figure 5-3). It is recommended to install one/two rows of tactile guidance tiles along the entire length of the proposed accessible route (Figure 5-1). Care must be taken to ensure that there are no obstacles, such as trees, poles or uneven surfaces, along

the route traversed by the guidance blocks. Also, there should be clear headroom of at least 2.1 meters height above the tactile guidance blocks, free of protruding objects such as overhanging tree branches and signage, along the entire length of the walk.

5.1.3.2 Tactile warning blocks (Dot-type)

This block indicates an approaching potential hazard or a change in direction of the walkway, and serve as a warning of the approaching danger to persons with visual impairments, preparing them to tread cautiously and expect obstacles along the travel path, traffic intersections, doorways, etc. (Figure 5-2). They are used to screen off obstacles, drop-offs or other hazards, to discourage movement in an incorrect direction, and to warn of a corner or junction. Two rows of tactile warning tiles should be installed across the entire width of the designated accessible pathway, before intersections, building entrances, obstacles such as trees, and each time the walkway changes direction (Figure 5-4). Warning blocks should be placed 300mm at the beginning and end of the ramps & stairs, at landings and entrance to any door.



Figure 5-1: Chequered tile on footpath

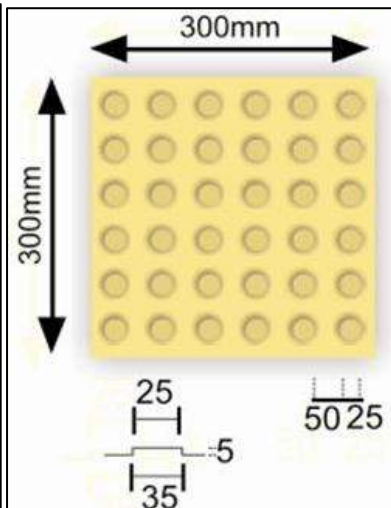

Figure 5-1: Warning blocks

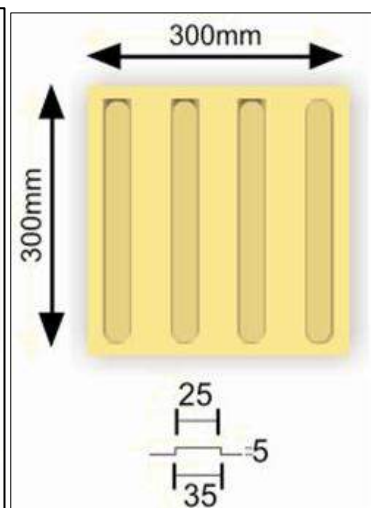
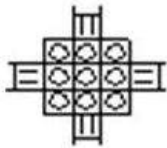
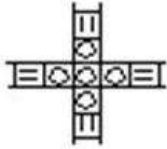

Figure 5-3: Guiding blocks

Arrangement of guiding blocks for persons with visual impairment

EXAMPLE OF INTERSECTION



EXAMPLE OF L-SHAPED INTERSECTION

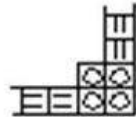

EXAMPLE OF T-SHAPED INTERSECTION

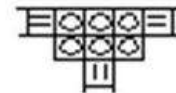
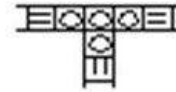

Guiding path and approaching sidewalk to the building

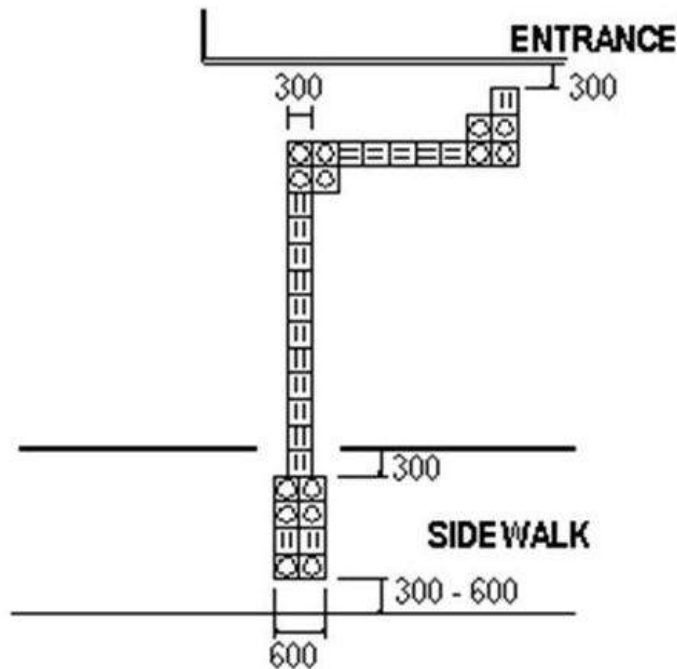

Figure 5-2: Configuration and layout of tactile pavers: guiding and warning

5.1.4 Barriers and hazards

Obstacles such as lighting columns, bollards, signposts, seats and trees, should be located at or beyond the boundaries of walkways. Where unavoidable, protruding objects should not reduce the clear width of an accessible route or maneuvering space.

- Protruding objects in the access route should contrast visually with the background environment.
- Free-standing columns that support an entrance canopy and low level posts, e.g. bollards, should not be positioned within the width of an access route.
- Free standing columns and posts within an access route should incorporate a band of 200 mm, between heights of 1400 mm and 1600 mm from the walkway floor finish, and which contrasts visually with the remainder of the post or column.
- Bollards should be avoided but where necessary be at least 1000 mm high, provide a wheelchair passage width of at least 900 mm (Figure 5-5), and should not be linked with chains.

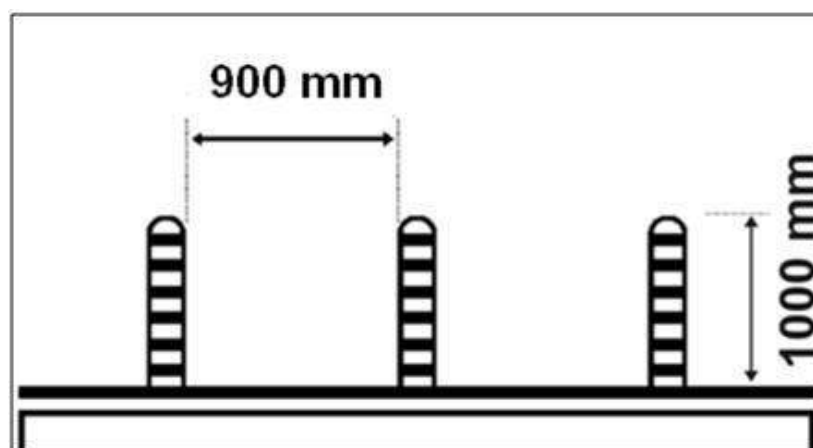

Figure 5-3: Bollards with spacing for wheelchair users/prams

5.1.4.1 Protruding objects

- Objects projecting with the lower edge of the projection at or below 300 mm and upper edge of the projection minimally 1200 mm above the finished walk surface are detectable by the white cane, and these may protrude into the walks to an extent that allows wheelchair passage.
- Objects mounted with their leading edges between 300 mm and 2200 mm above the finished walk surface should not protrude more than 100 mm (Figure 5-6) into the walks.
- Hazard protection should be provided if objects project more than 100 mm into an access route and their lower edge is more than 300 mm above the ground. Hazard protection associated with such objects should take the form of a kerb or other solid barrier so that person with visual impairment can detect the hazard using a cane. The hazard protection should not extend beyond the front edge of the object, nor should it be set back more than 100 mm from its front edge.

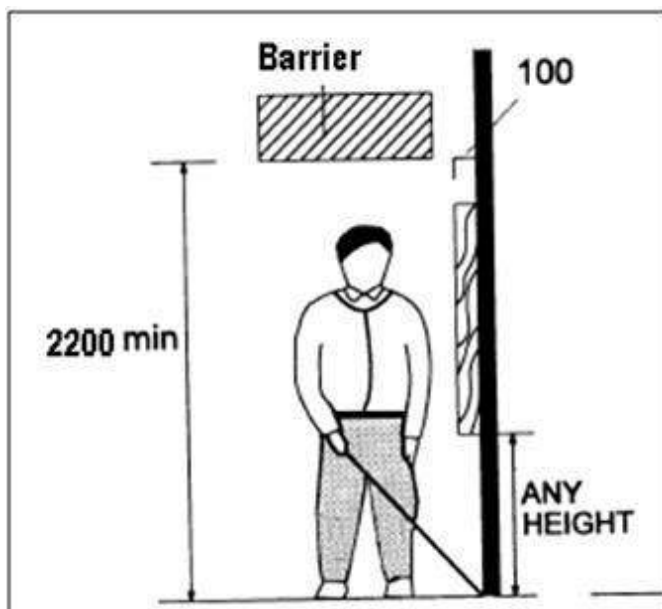

Figure 5-5: Protruding obstacles placed in a niche

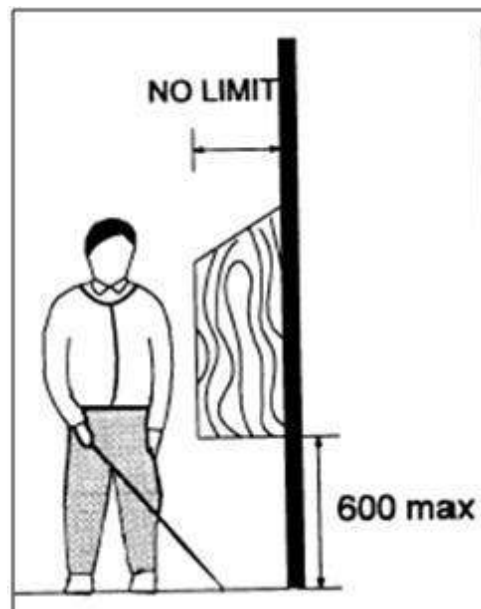

Figure 5-4: Clearance from protruding obstacles

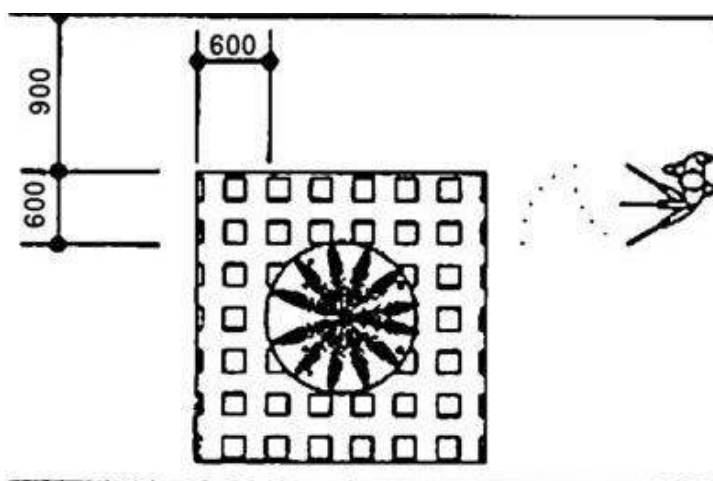

Figure 5-6: Placement of obstacles outside path of travel

5.1.5 Kerb ramp

Where pathways meet the road a kerb ramp is required. The kerb ramp should conform to specification given in Section 7.1. Where pathways meet the road / a kerb ramp is provided and any crossing involved, a tactile pathway along the road crossing shall be provided for persons with visual impairments.

5.1.6 Typical detail of walkway

- Minimum width of the walkway should be 1800mm (Figure 5-9).
- Walkway should be constructed with a non-slip material and surface should be different from rest of the area.
- The walkway should be cross vehicular traffic.
- Warning blocks at 300mm before and after finishing of the walkway should be provided.

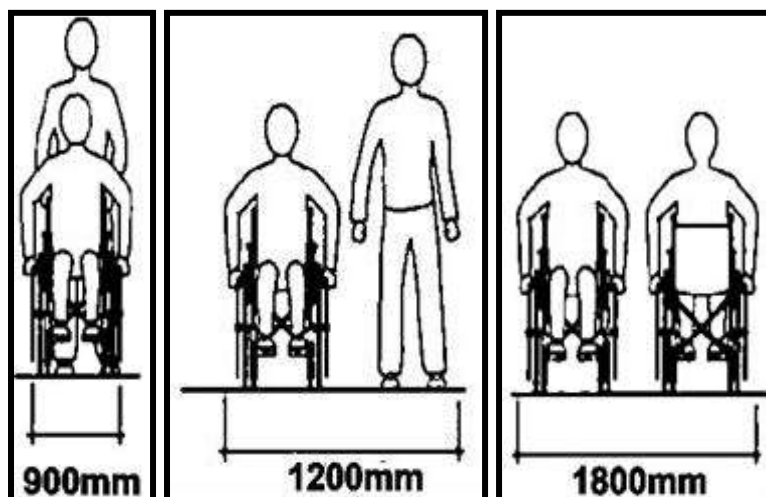

Figure 5-7: Minimum width of a clear walkway

5.1.7 Parking

There shall be reserved parking for persons with disability within 30m of accessible entrances. For details of parking layout and number of parking places refer to Section 10.1.5.

5.1.8 Lighting for walkways

- Lighting should illuminate the walkway; lighting fixtures not exceeding a height of 4m from ground level should be provided.
- Lighting must be provided every 20 – 30m, focusing light not on the car lanes, but on the walkways.
- A whiter light source, for example high-pressure sodium, is preferable in city and town centers for the aesthetic effect and for better colour definition, which benefits those with poor sight.
- White lighting at average 35-40 lux is recommended to ensure colour contrast of tactile pavers and visible at night to persons with low vision.
- Under no circumstances the lighting pole should interfere with the clearance of the walkway.
- Light pole may preferably be located within the tree-planting zone.
- Lower level light poles are preferred to avoid shadow where there are high trees.

5.2 Space allowances

For persons using mobility aids/ white cane, space allowance complying with Section 3.1 should be provided.

5.3 Floor surfaces

5.3.1. Floor surface should be stable, firm, level and slip-resistant and preferably matt finish and should not have any projections, drops, or unexpected variation in level. Also:

- Complex patterns should be avoided.
- Floor patterns that could be mistaken for steps, for example stripes, should not be used for floors in corridors.
- Floors should be levelled. If this is unavoidable, the slope of floors should be no greater than 1:20. If greater, floor should be designed as ramp.

5.3.2 For people with low vision, lines of brightly coloured tape may be placed on the floor surface to assist mobility in poorly lighted areas.

5.3.3. Where carpets are used in circulation area, they should:

- Be securely fixed
- Have firm cushion, pad or backing; and
- Have exposed edges of carpets fastened to floor surface and trim along the entire length of the exposed edge.

5.4 Approaches

5.4.1 Approach to building

- A passenger alighting and boarding point complying with Section 10.1 and 10.2 should, be provided at the level of approach for Persons with Disabilities to alight from and board a vehicle.
- Where transfers have to be made from a vehicular surface to a pedestrian surface, the driveway and the pavement or footpath surfaces should be blended to a common level or ramped.
- Difference in level between the driveway and footpath level surface should be avoided. Where the difference is unavoidable, such drop shall have a kerb ramp (Section 7.1).

5.4.2 Passenger alighting and drop off points

A passenger alighting and boarding point as illustrated in the figure should:

- provide an access aisle of at least 1500mm wide by 6000mm long adjacent and parallel to the vehicle pull-up space;
- the accessible aisle must be at the same level as the vehicle
- have a kerb ramp complying with Section 7.1 if there are kerbs between the access aisle and the vehicle pull-up space;
- wherever possible, be sheltered and have identification signage (symbol of accessibility) for alighting area (Section 6.4.7.5).
- Tactile floor guidance be provided from the building drop off area leading up to entrance of the building.

5.4.3 Access to building

- An access route should be provided connecting all major entrances & exits of the building from the alighting and boarding point of taxi stands and car park lots for Persons with Disabilities.
- The building should have all accessible entrance doors served by an approach complying with (Section 5.4).
- In multi storey buildings, the accessible entrance must have an accessible route leading to the elevators.
- The accessible entrance, if different from the main entrance, should be located adjacent to the main entrance and not at the rear of the building. The accessible entrance should be clearly signed and easy to locate.
- Symbol should be displayed at all other non-accessible entrances to direct Persons with Disabilities to the accessible entrance.

- A clear, firm and level landing of at least 1800mm x 1800mm should be provided on either side of the entrance door.
- The clear width of the accessible entrance door should not be less than 900mm (Figure 5-10), preferable 1m and the width of the corridors or passageways leading to and from such access door should not be less than 1200mm
- Internal floor surfaces should be anti-skid/ non-slip and of materials that do not impede the movement of wheelchairs/other mobility aids.

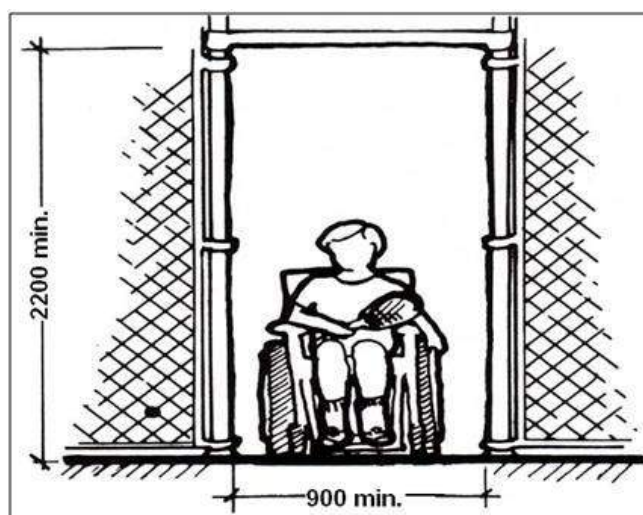

Figure 5-8: Door opening

- If mat is provided it should be flushed with the floor finish.
- Persons with visual impairments find it easier to locate doors if there is a texture difference in the floor around the doorway from the rest of the flooring. It is generally good practice to recess foot mats in the floor on either side of the door but care must be taken to ensure that the top end of the mats are flush with the rest of the flooring.
- In addition to tactile pavers leading to the main entrances, beepers may be put at all main entrances to enable people with visual impairments to locate them.
- A tactile layout plan of the building along with Braille and audio systems should be provided at the entrance for people with visual impairments.
- Glazed entrance doors must have manifestations on the glass preferably at two levels i.e. one between 800 to 1000mm and another between 1400 to 1600mm above the floor.
- The manifestation should be contrasting in colour from the immediate background and be minimally 150mm high (Section 5.7.16).

5.5 Internal Corridors and Accessible Routes

5.5.1 Width

- The minimum clear width of an accessible route should be 1500mm minimum to allow both a wheelchair and a walking person to pass (Section 5.1.6) except when additional manoeuvring space is required at doorways.
- Where space is required for two wheelchairs to pass, the minimum clear width should be 1800mm.

5.5.2 Resting benches/seats

- In long paths of travel resting areas should be provided at frequent intervals not exceeding 30 meters complying with Section 5.11.

5.5.3 Protruding objects

- Obstacles, projections or other protrusions should be avoided in pedestrian areas such as walkways, halls, corridors, passageways or aisles (Figure 5-6, 5-7 and 5-8).

5.5.4 Floor surfaces in corridors

- Avoid carpeting. If carpet is used, it should be fixed firmly with a pile not higher than 12mm (Section 5.3.3).

5.5.5 Lighting in corridors

- Lighting in a corridor should be even, diffused and without glare, reflections or shadows.
- Minimum illumination level in the corridor should be 150 lux.

5.5.6 Doors leading into corridors

- Doors should not open outwards from rooms directly into a frequently used corridor, with the exception of doors to accessible toilets and service ducts.
- Where a door opens into an infrequently used corridor such as emergency exit, the corridor width should allow a clear space of 900 mm within the corridor when the door is open (Section 5.7). Such doors should be located clear of any sloping floor surfaces in the corridor.
- Any door that opens towards a frequently used corridor should be located in a recess at least as deep as the width of the door leaf.
- The leading edge of any door that is likely to be held open should “contrast visually” with the remaining surfaces of the door and its surroundings to help identification by visually impaired people. The architrave should contrast visually with the wall surfaces surrounding the doorway.

5.5.7 Tactile guidance Path along the internal corridors and accessible routes

Along the accessible corridor and route connecting the entire building, a tactile floor guidance path for independent movement of persons with visual impairments should be provided. Tactile guidance path have to be laid out in the entire building premises connecting all the public utilities and locations and building entrance and exits.

5.6 Gratings

5.6.1 Grating located along the exterior circulation should:

- Preferably be covered;
- Have spaces not greater than 12 mm wide in one direction (Figure 5-11); and
- Have long dimension across the dominant direction of travel as illustrated in the Figure 5-12.

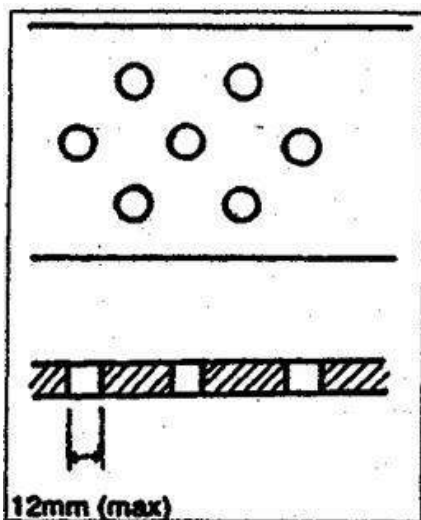

Figure 5-10: Grating Width

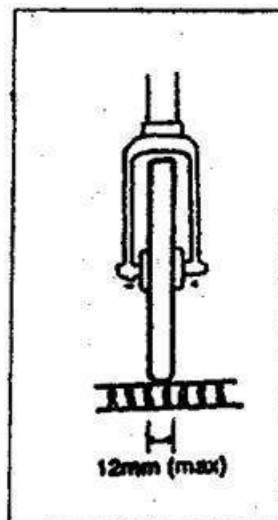

Figure 5-9: Wheelchair Castor Width



Figure 5-11: Preferred design of gratings

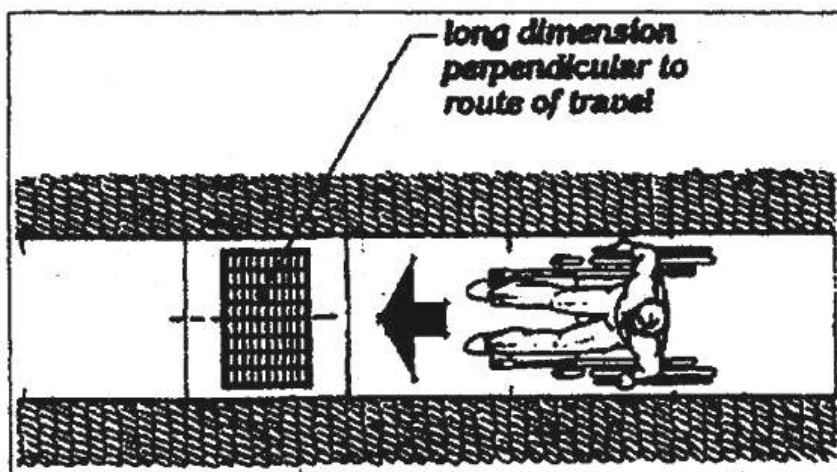

Figure 5-12: Installation Guide

5.7 Doors

5.7.1 General

- Doorways should be levelled.
- Wherever revolving doors or turnstiles are installed they should be supplemented with an auxiliary side-hung (swing type) door with 900mm minimum clear opening width.

- Bathroom (toilets/washroom) doors should swing out/ should be two way opening type so that the person inside does not fall against the door and block it. In case there is not much space available, consideration should be given to the use of sliding or folding doors, which are easier to operate and require less wheelchair manoeuvring space.
- Door should not be too heavy to operate and should not require a force of more than 20 N to operate.
- Automatic doors should have a push button system to open them.
- All external doors should have warning blocks installed 300mm before entrances.

5.7.2 Clear width

The minimum clear opening of doorways should be 900mm, measured between the face of the door and the face of the door stop with the door open at 90°.

5.7.3 Thresholds

- There should be no thresholds.
- If thresholds are unavoidable, they should not exceed 12 mm and those exceeding 5 mm should be beveled.

5.7.4 Double-leaf doors

In case the door has two independently operated door leaves, at least one active leaf should comply with Section 5.7.2.

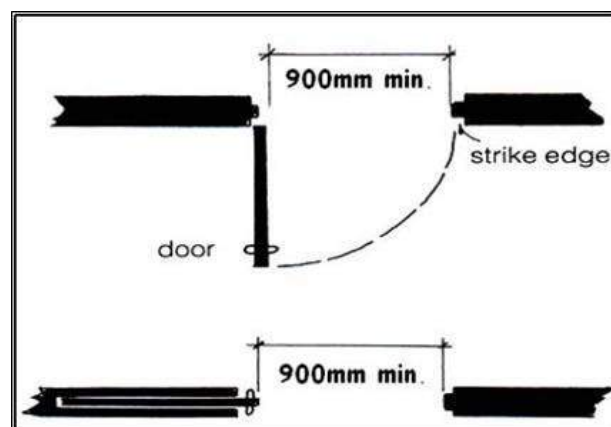

Figure 5-13: Clear door width

5.7.5 Maneuvering space at doors

- A distance of 650 mm should be provided beyond the leading edge of door to enable a wheelchair user to maneuver and to reach the handle.
- Wheelchair manoeuvring spaces should be free of any obstructions and space should be provided on the side of the door handle (Figure 5-16) in the following manner:
 - On the pull side, a minimum space of 650 mm;
 - On the push side, a minimum space of 300 mm;
 - For two-way swing door, a minimum space of 300mm.

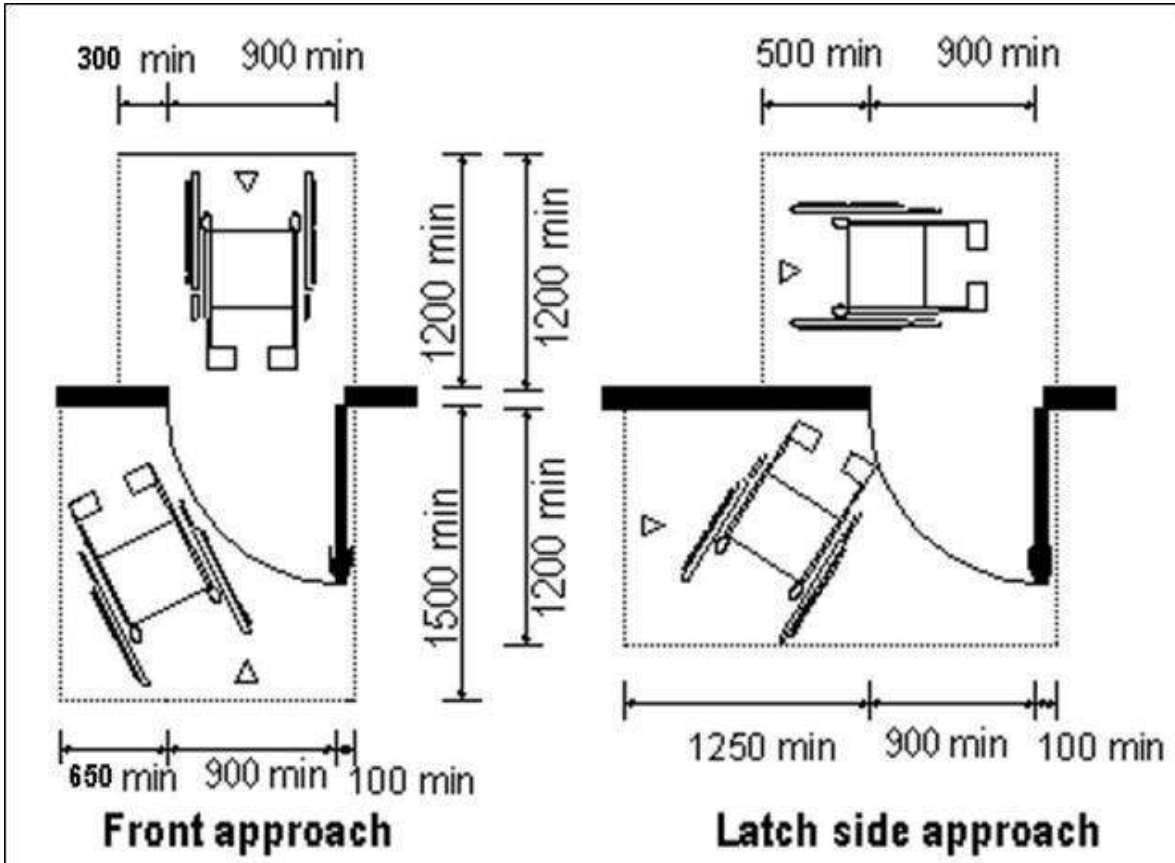

Figure 5-14: Maneuvering space needed for wheelchair users to approach doors

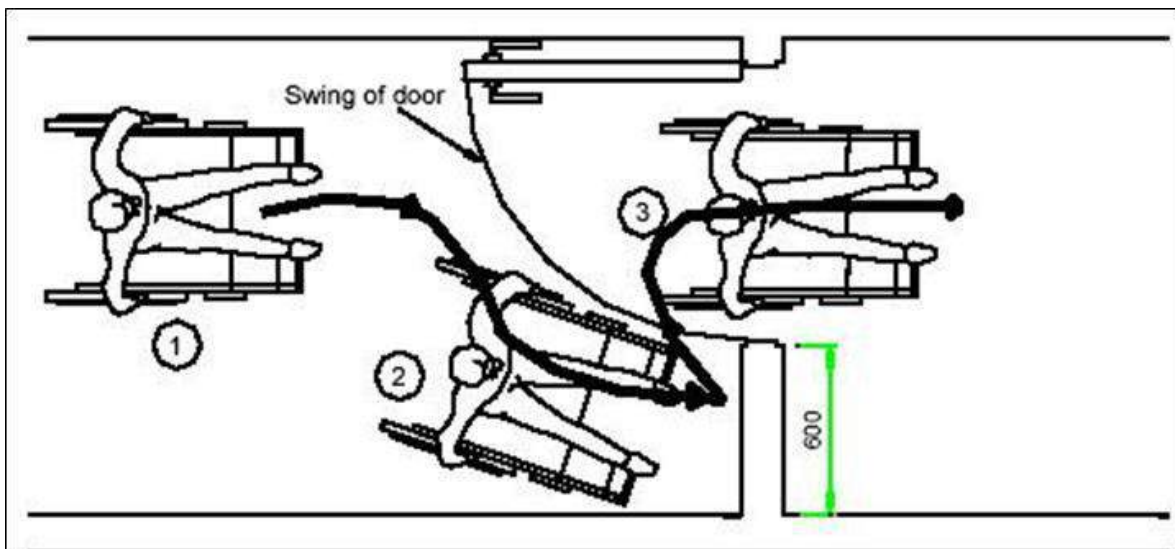

Figure 5-15: Position taken by wheelchair when negotiating door in passageway

5.7.6 Two doors in series

The minimum space between two hinged or pivoted doors in series should be 1200 mm plus the width of the door swinging into that space (Figure 5-18).

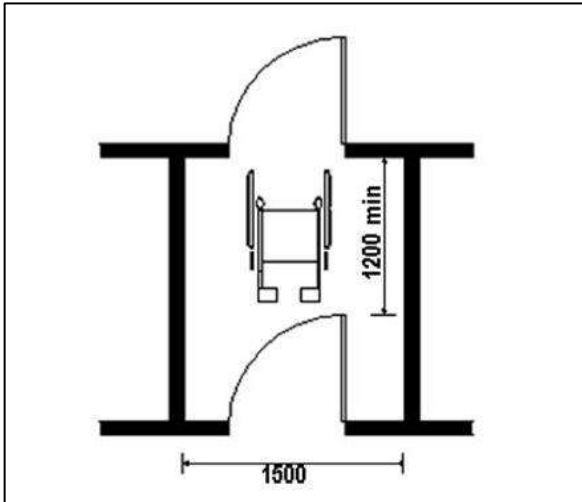

Figure 5-16: Space between two doors

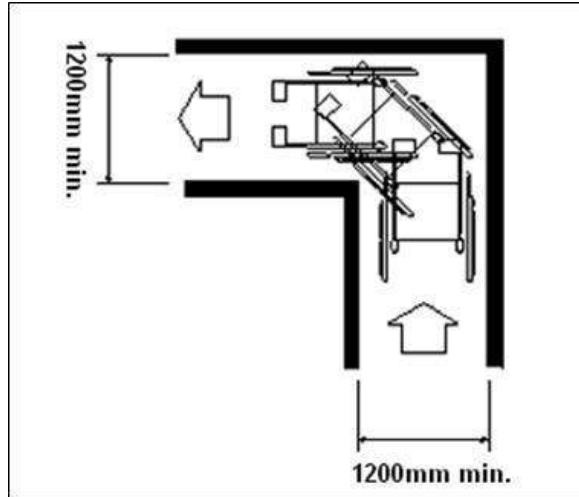

Figure 5-17: Space for wheelchair in 90° turn

5.7.7 Wheelchair maneuvering space

- To enable wheelchair users to approach doors maneuvering space is needed (Figure 5-19) corridor should have a width of at least 1200 mm to allow a 90° turn to be made through a door. In narrow spaces sliding doors may be preferable.

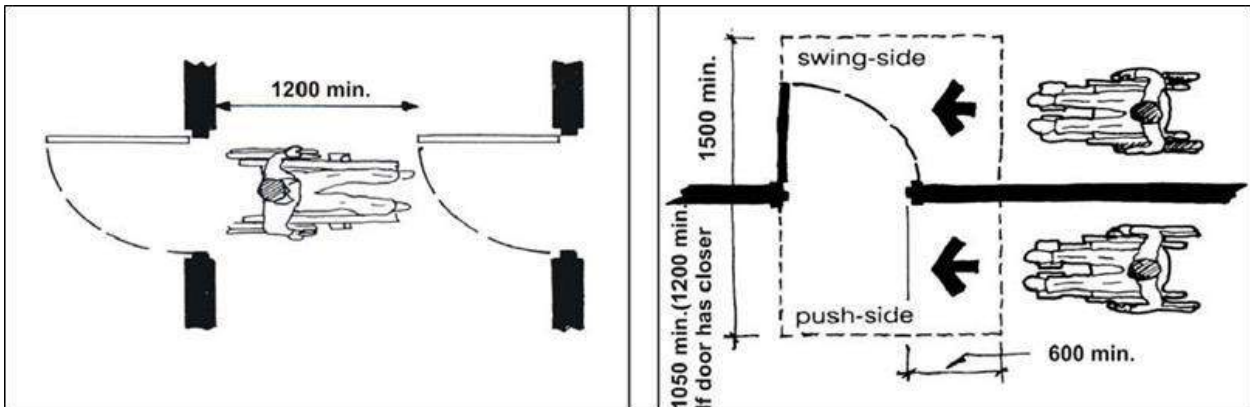

Figure 5-19: Maneuvering space needed for wheelchair users to approach doors

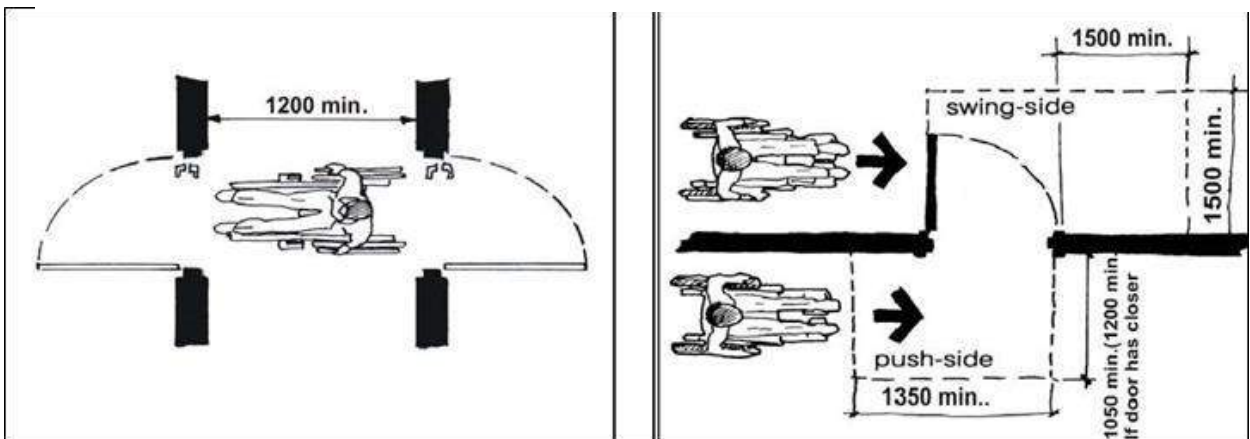

Figure 5-18: Maneuvering space needed for approach doors

5.7.8 Door hardware

Operable devices such as handles, pulls, latches and locks (figure 5-22) should:-

- Be operable by one hand;
- Not require fine finger control, tight grasping, pinching or twisting to operate; and
- Be mounted at a height of 850 mm to 1100mm from the floor.
- For easy identification by persons with visual impairment all door furniture should contrast visually with the surface of the door.
- The location and design of latch and push/pull handles should be consistent throughout a building.
- To facilitate the closing of a door by wheelchair users (for example, a water-closet compartment, that does not have a self-closing mechanism), the door should have a horizontal handle, provided on the closing face of the door, approximately 760 mm from the floor.

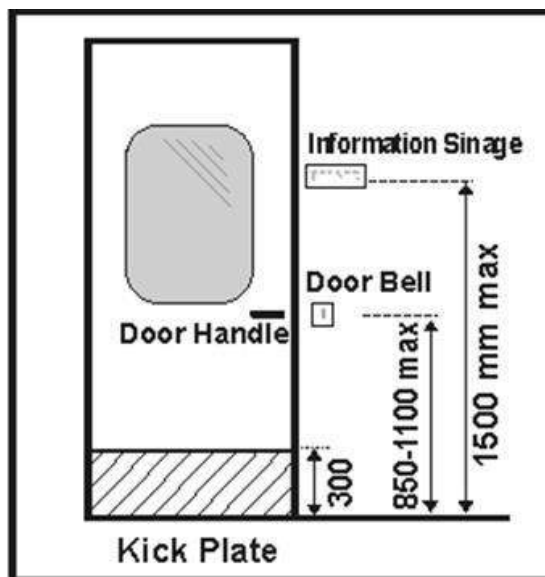

Figure 5-20: Door hardware location

5.7.9 Door handles

The following characteristics are recommended:

- Push –pull mechanisms that require no grasping;
- Lever handles to be preferred on latched doors;
- It is safer to use D shaped handles as they reduce the risk of catching on clothing, or injuring from the exposed lever end.
- Doorknob is not recommended, as it does not provide adequate grip for persons with impaired hand functions

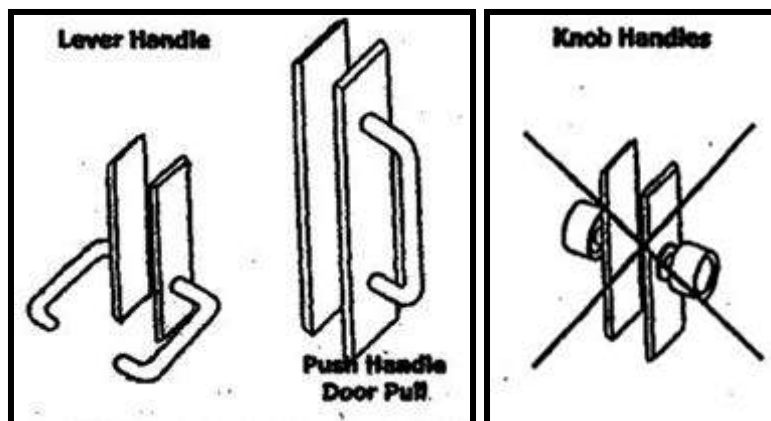

Figure 5-21: Preferred door handles

5.7.10 Sliding/folding doors

Operating hardware should be exposed and usable from both the sides when the door is fully open.

5.7.11 Door opening force

The maximum force for pushing or pulling or sliding a door should be 20N.

5.7.12 Door closure

The sweep period of the door should be adjusted, so that from an open position of 90degrees the door does not take less than 3 seconds to move to a semi-closed position.

5.7.13 Vision panel

All two-way swing doors or doors in general circulation areas should be provided with vision panels giving a visibility from a height of 800 mm to 1500 mm. This will enable both the wheelchair user and the ambulatory disabled to be noticed by a person on the opposite side in order to prevent him/her from being accidentally struck by the door.

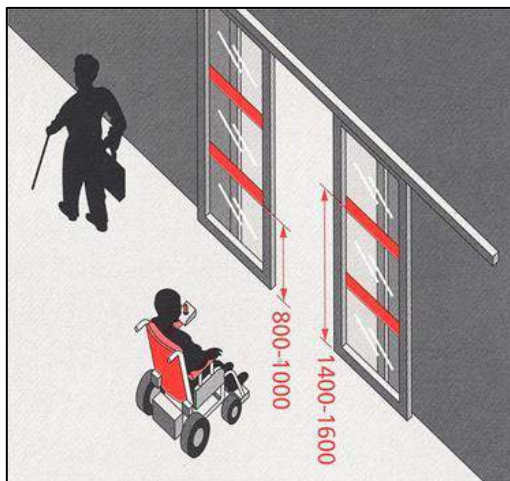

Figure 5-22: Glass door markings

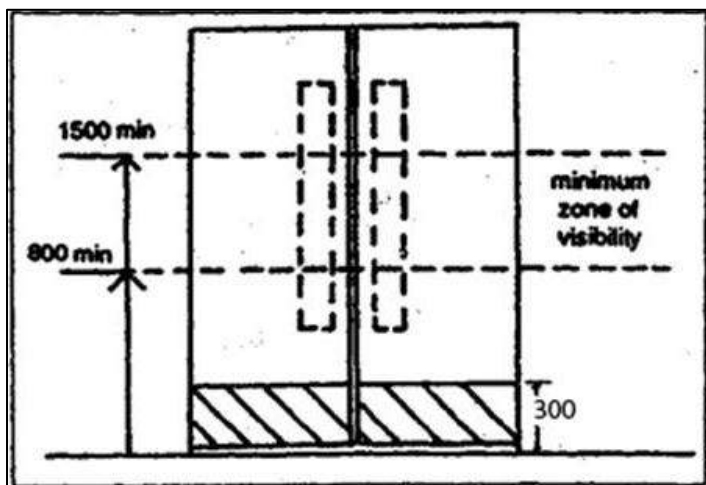

Figure 5-23: Recommended visibility zone

5.7.13.1 Kick-plate

- Kick- plates of 300-400 mm height (Figure 5-25) are recommended for doors in high-use in order to protect the push side of doors from damage.

5.7.13.2 Door identification

- To help people with impaired sight to see doors, the door and frame should be in a colour which contrasts with the adjoining wall.

- The door should not be of a highly polished/ reflective material such as stainless steel.

5.7.13.3 Glass doors

The presence of a glass door should be made apparent, with permanent manifestation at two levels, within 800 mm to 1000 mm from the floor and within 1400 mm to 1600 mm from the floor (Figure 5-24), contrasting visually with the

background seen through the glass in all light conditions. The edges of a glass door should also be apparent when the door is open.

Note: If a glass door is adjacent to, or is incorporated within, a fully glazed wall, the door and wall should be clearly differentiated from one another, with the door more prominent. To achieve this, the door may be framed on both sides and the top by an opaque high-contrast strip at least 25 mm wide.

5.8 Windows

- Windows should have handles/ controls in accordance to Section 5.10.2.
- Should provide an unobstructed viewing zone for wheelchair users between 600mm and 1400mm.
- Curtain or Venetian blind controls/ropes should be at 800-1000 mm height (Figure 5-24) from the finished floor level for wheelchair users/short stature persons.

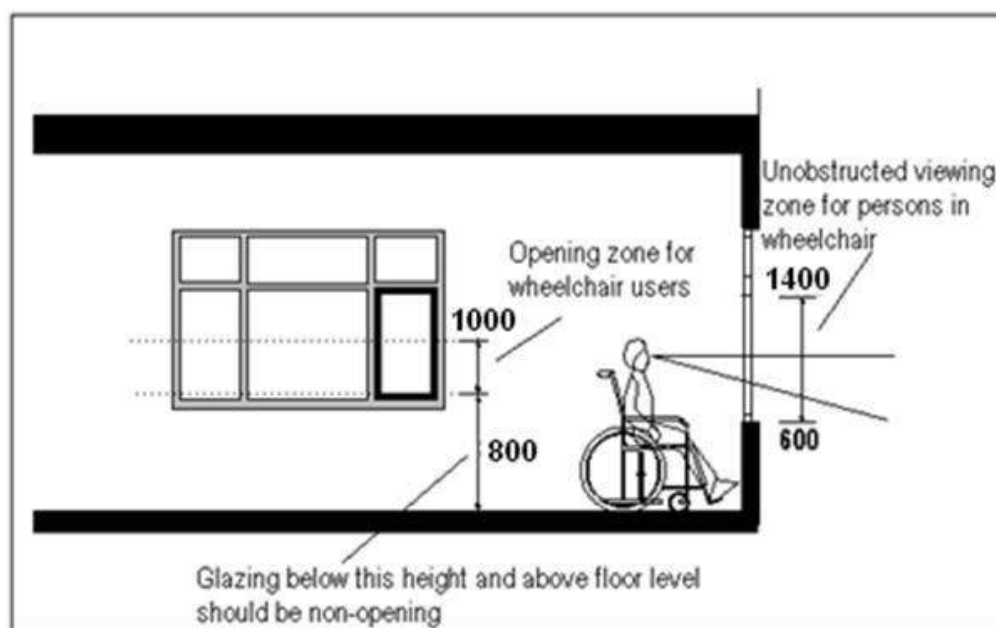

Figure 5-24: Standards for accessible window

5.9 Handrail/ Grab Bars

5.9.1 General

- Handrails/ grab bars are extremely important features and must be designed to be easy to grasp and to provide a firm and comfortable grip so that the hand can slide along the rail without obstruction.
- Many Persons with Disabilities and elderly rely upon handrails/ grab bars to maintain balance or prevent serious falls.
- Handrails may be provided with Braille/ tactile markings (Figure 5-27) at the beginning and the end to give information to people with visual impairment.



Figure 5-25: Handrail with Braille Information Panel

5.9.2 Handrail should:

- be slip-resistant with round ends;
- have a circular section of 38-45 mm in diameter (Figure 5-28);
- have a minimum clear space of 50 mm from the walls (Figure 5-28);
- be free of any sharp or abrasive elements; and
- have continuous gripping surfaces, without interruptions or obstructions that can break a hand hold.

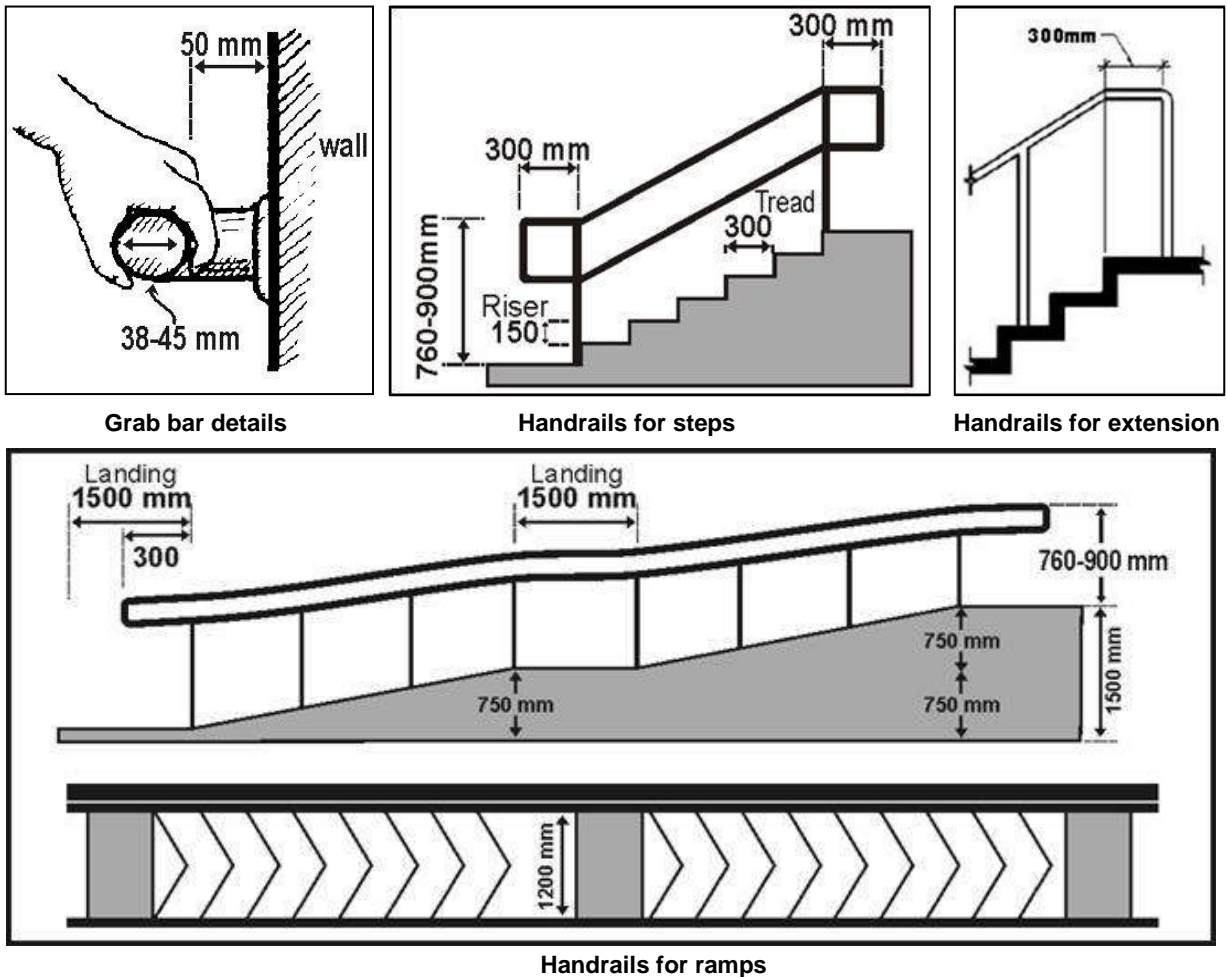

Figure 5-26: Handrail standards

5.9.3 Grab Bars

Grab bars/ rails should be manufactured from a material which contrasts with the wall finish (or use dark tiles behind light coloured rails), be not too warm/cold to the touch and provide good grip. It is essential that all grab rails are adequately fixed, since considerable pressure will be placed on the rail during maneuvering. In rural areas, indigenous materials such as bamboo/ wood/ other can be used for making grab bars in toilets.

Grab bars should:-

- be slip-resistant with round ends;
- preferably have knurled surfaces;
- have a circular section of 38-45 mm in diameter;
- be free of any sharp or abrasive elements;
- have a minimum clear space of 50 mm from the wall;
- be installed at a height of 760 mm to 900 mm;
- be able to bear a weight of 250 kg.

5.10 Controls and Operating Mechanism

5.10.1 Clear Floor Space

- A clear and level floor space of at least 900 mm x 1200 mm (Figure 5-29) should be provided at controls and operating mechanisms designated for use by Persons with Disabilities.
- Where a forward approach is used, a clear knee space of at least 900 mm wide, 480 mm deep and 650 mm high should be provided, which may overlap the clear floor space by a maximum of 480 mm.

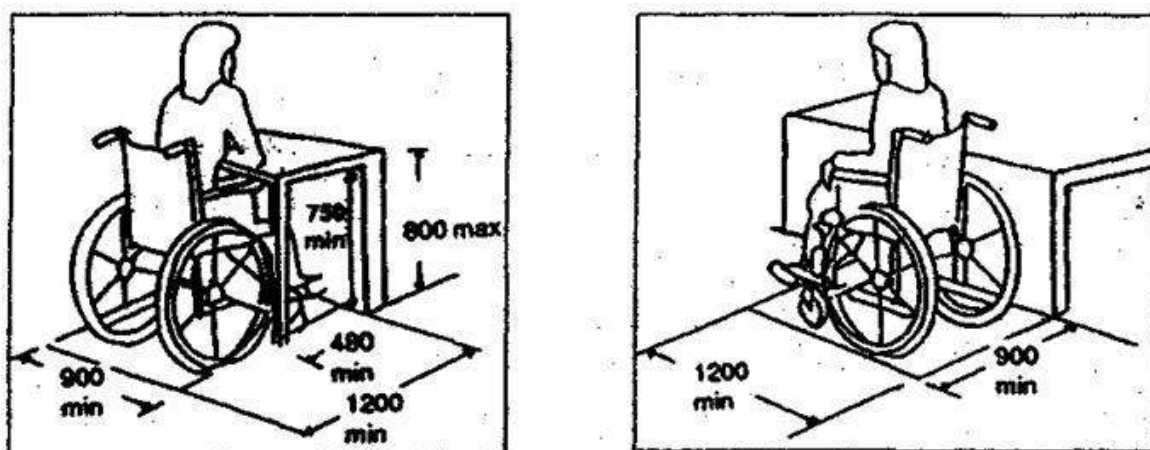

Figure 5-27: Space clearance for control operations

5.10.2 Electrical points, Controls and Outlets

The operable part of controls such as vending machines, electrical switches, wall sockets and intercom buttons should be:

- located adjacent to the clear floor space;
- located at a height of between 600 mm to 1100 mm (Figure 5-30) from the floor with the exception of vending machines where the upper limit is relaxable by a maximum of 100 mm;
- to cater for wheelchair users, controls should be placed not less than 400 mm from room corners.;
- operable by one hand;
- of a type that does not require tight grasping, pinching or twisting of the wrist; and
- operable with a force less than 22N.

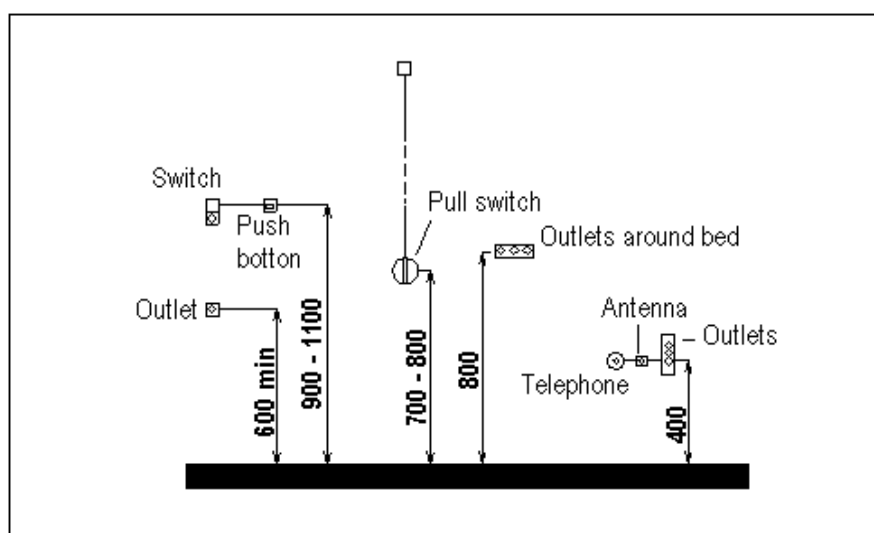

Figure 5-28: Location of electrical sockets, control, etc.

5.10.3 Faucets/taps

Faucets and other controls designated for use by Persons with Disabilities should be hand-operated or electronically controlled.

- Hand-operated controls should:
 - be operable by one hand;
 - require no tight grasping, pinching or twisting of the wrist;
 - require a force less than 22 N to activate; and
 - have handles of lever type (not self-closing) operable with a closed fist (Figure 5-31 and Figure 5-32).



Figure 5-30: Lever handle tap



Figure 5-29: Long handle tap

- To cater for visually impaired people, controls should be colour-contrasted with the surrounding face plate panel and the face plate should similarly contrast with the background wall on which it is mounted. Information should preferably be in relief (embossed letters/ symbols accompanied with Braille information) for tactile reading.
- To aid operation for people with impaired co-ordination or impaired sight, switches, etc, should have large push plates, operable by one hand

5.11 Seating Spaces

5.11.1 Clear Floor Space

Seating space, such as those provided at counters, tables, or work surfaces for persons in wheelchairs should have a clear and level floor space of not less than 900 mm x 1200 mm (Figure 5-33) complying with Section 5.10.1.

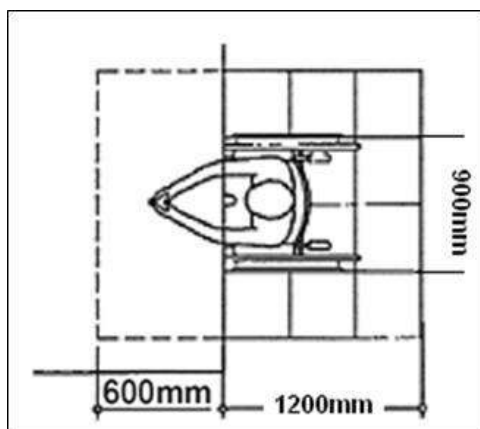

Figure 5-31: Clear floor space for wheelchair

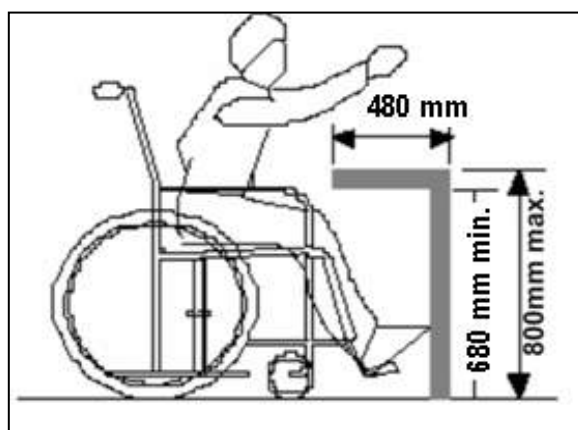

Figure 5-32: Counter tops/table height

5.11.2 Clear Knee Space

Where a forward approach is used, a clear knee space of at least 900 mm wide, 480 mm deep and 650 mm high should be provided, which may overlap the clear floor space by a maximum of 480 mm.

5.11.3 Counter Tops

Writing surfaces or service counters should not be more than 800 mm from the floor and have clear knee space of 680mm (Figure 5-34).

5.12 Other Facilities

5.12.1 Drinking Water Fountain

Drinking water fountain/unit should have:

- Controls complying with Section 5.10.
- drinking water coolers or taps should:
- have a clear floor space of at least 900mm x 1200mm as (Figure 5-35);
 - have a clear knee space between the bottom of the apron and floor or ground of at least 750mm wide, 200mm deep and 680mm high (Figure 5-35);
 - have a toe space not less than 750mm wide, 230mm high
 - have a water glass provision;
 - free standing or built -in-drinking water coolers or taps not having a knee space should have a clear floor space of at least 1200mm wide x 1200mm in front of the unit (Figure 5-35);
- All wall-mounted drinking water provision in an alcove is preferred, because it does not create a hazard for persons with visual impairments.
- The provision of two drinking facilities at different heights is very convenient for standing adults, people in wheelchairs and children.
- The 100mm high water flow is to allow for the insertion of a cup or glass.

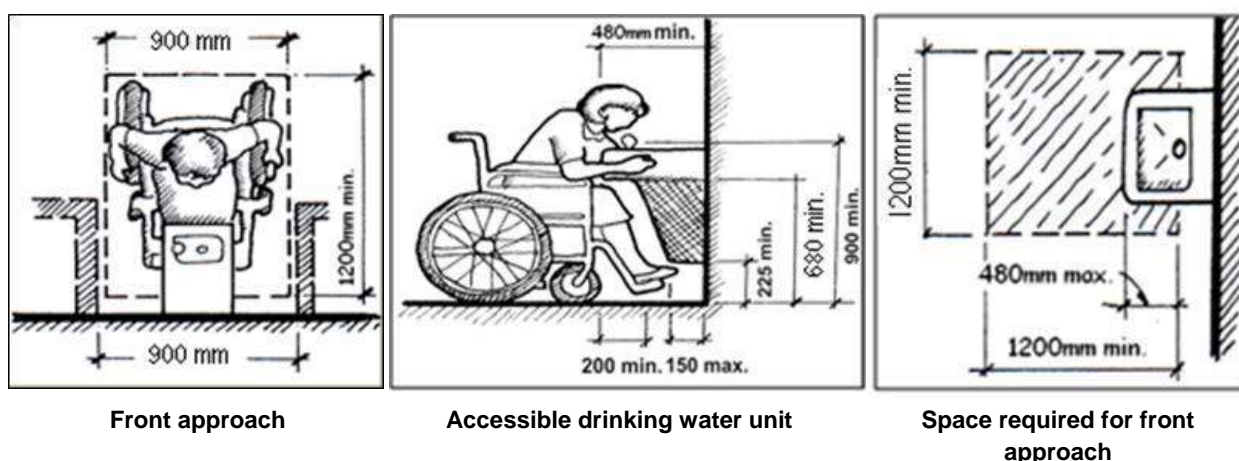

Figure 5-33: Drinking water fountain

5.12.2 Public Telephone

5.12.2.1 General

- Where payphones are provided, at least one payphone should be made accessible.

5.12.2.2 Clear Space

- A clear space of not less than 900mm by 1200mm should be provided in front of the telephone booth or counter (Figure 5-37).

5.12.2.3 Counter Top

- Counter tops, where provided, should be between 650mm and 800mm from the floor and have a minimum clear knee space of 680mm high (Figure 5-38).
- The depth of the counter top should be not less than 480mm.

5.12.2.4 Telephone Booth

- The opening of the telephone booth should have a clear width of at least 900mm.
- The enclosed space should have dimensions of at least 900mm by 1200mm that should not be restricted by fixed seats (Figure 5-37).

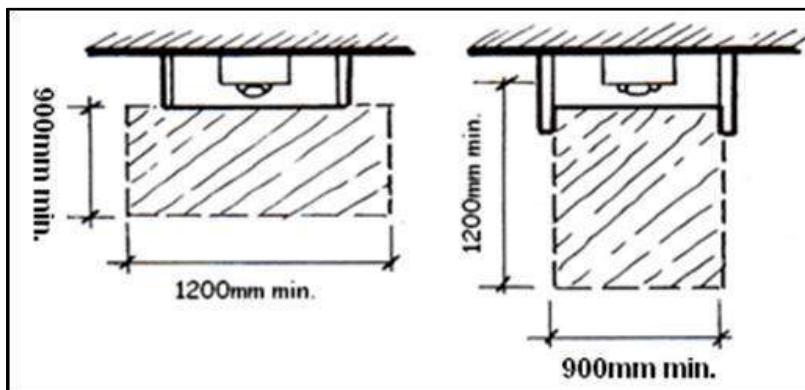

Figure 5-35: Space allowance for telephone counter

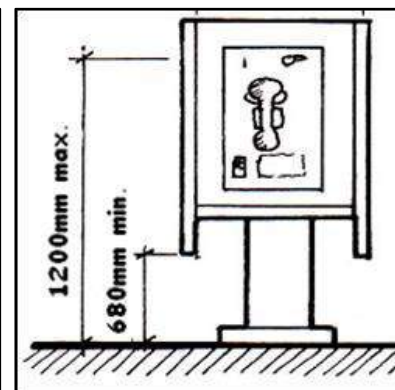

Figure 5-34: Telephone height

5.12.2.5 Height

- The height of all operable parts of the telephone should be between 800mm and 1200mm

5.12.2.6 Telephone Cord

- The minimum length of the cord should be 900mm

5.12.2.7 Signage

- The International Symbol of Access should be displayed to identify the location of such telephones (Figure 5-38).



Figure 5-36: Accessible public telephone

5.12.2.8 Mailbox / Dropbox

- The mail / drop box slot should be located at the height of maximum 1200mm.
- It should have a clear floor space of 900 X 1200mm (Figure 5-38).

5.12.2.9 Vending Machine

- The coin slot must be located at height of 1200mm or less
- It should have a clear floor space of 900 X 1200 mm.
- Operating buttons should be in raised numbers and in contrasting colours.

5.12.2.10 ATM- Money Machine

- It should have a clear floor space of 1200X 1200 mm.
- Control buttons should be between 800mm and 1000mm height from the floor.
- Control buttons should be in raised numbers/ Braille and in contrasting colours.

5.13 Signage

- Should comply with specifications given in Chapter 6.

5.14 Level Changes

- Should comply with specifications given in Chapter 7.

5.15 Toilets

- Should comply with specifications given in Chapter 8.

5.16 Parking

- Should comply with specifications given in Chapter 10.

6 SIGNAGE

Signs are important to people who are unfamiliar with their surroundings. They are to provide information. They can inform the user of a route, a hazard, or a facility. Signs also communicate an identity for the building or environment they serve. Signage contributes greatly to the aesthetics and first impression of a building. Signs must be clear, concise, and consistent.

A signage system also increases person's awareness of their surroundings and aids orientation within the environment. The location of signs should ideally be part of the process of planning the building and environment. A good and successful sign system should minimize anxiety and confusion. It must be easy to understand and not place Persons with Disabilities at a disadvantage. Universal signage cuts across the regional/cultural and language barriers as even a common lay man can understand the symbols and pictograms.

People need clear information about the purpose and layout of spaces to maintain a sense of direction and independent use of a building. Often visual and tactile information is reinforced by audible information. Information may take the form of visual information (e.g. signs, notice boards), audible information (e.g. public address and security systems, induction loops, telephones, and infrared devices), or tactile information (e.g. signs with embossed lettering or Braille).

The effectiveness of information on the use of a building is determined by:

- a. the location, accessibility, layout and height of signs;
- b. the size of lettering, symbols and their reading distances;
- c. the use of tactile letters and symbols;
- d. visual contrast and lighting;
- e. the finished surfaces of materials used for signs and symbols;
- f. the simultaneous use of audible cues;
- g. integration with any other communication systems.

6.1 Signage Provisions

- Information and direction signs should be provided at junctions of circulation routes and key destinations such as doorways, at reception points, at facilities such as telephones, drinking water facility, toilets, and in areas where hearing enhancement systems are fitted.
- Directional signs should readily identify and provide a logical sequence from a starting point to a point of destination and a clear indication of return routes to named exits. The names of destinations should be consistent throughout the signing system.
- A clear indication of the existence of steps or ramps on a route should be provided at both ends of the route.

- Signs to facilities for Persons with Disabilities should incorporate the International Symbol for Accessibility (Section 6.4.7.5).
- A building should include spaces where announcements can be transmitted through a hearing enhancement system. Signs should be provided to inform persons with hearing impairment of locations in the building where these systems are fitted, and where they can obtain the necessary equipment for hearing enhancement systems.
- Universally recognized symbols/pictograms should be used to replace text, wherever possible. Other symbols should supplement text, but should not be used in isolation. Symbols are an essential aid for people with learning difficulties.
- A wall mounted or ceiling hung information board should be provided at lift landings, floor level landings of staircases, and at other major decision points (junctions/intersections) in main circulation routes.

6.2 Types of Signages

According to the purposes it serves, Signage can be of following types:

- (a) Directional
- (b) Information
- (c) Identification
- (d) Instructive
- (e) Health & Safety

6.2.1 Directional Signage

(For Way-finding- with arrows along travel routes) are usually wall mounted or overhead signs and include directional arrows to direct users to specific areas or elements within an area (Figure6-1). This can incorporate provision of signage at navigational decision points.



Figure 6-1: Directional signage for ramp



Figure 6-2: Directional signage for rooms

6.2.2 Information

(Provide detailed info- includes maps & directories with 'You are Here' labels) inform users about the features and facilities of a place or space. Information signs include directions, maps, building identification signs, notices and interpretative signs.



Figure 6-4: Information signage



Figure 6-3: Destination signage



6.2.3 Identification

(To signify arrival. Also called Destination Sign) usually identify entrances, street addresses, buildings, rooms, facilities, places and spaces.

6.2.4 Instructive

(To give instruction for operating a device, way finding, etc.)

6.2.5 Health & Safety

(Provide lifesaving directives and/ or mandatory rules to be followed)



Figure 6-5: Instructive signs



Figure 6-6: Mandatory signs

6.3 Location

- Signs should be provided at all sites, campus, developments and buildings in appropriate locations including approach to building / facility / service, entrance / exit, main lobby or reception, public facilities such as library, toilets etc., departments and offices, fire exits and parking and garages.

A good signage scheme should cover all public buildings, spaces, and facilities including transportation infrastructure and should include locations such as :

- a. Approach to building / facility / service
- b. Entrance / exit
- c. Main lobby or reception
- d. Public facilities such as library, toilets etc.
- e. Departments and offices
- f. Fire exits
- g. Parking and garages

6.4 Universal Signage

To make signage universally usable, following components must be kept in mind:

- a. Colour contrast Signs
- b. Character, Content and Layout
- c. Pictograms and accessibility symbols
- d. Positioning
- e. Viewing Distance
- f. Lighting (measured in lux)
- g. Material and surface finish
- h. Alternative formats etc. embossed letters with Braille (Audio/ Visual information, Maps and models)

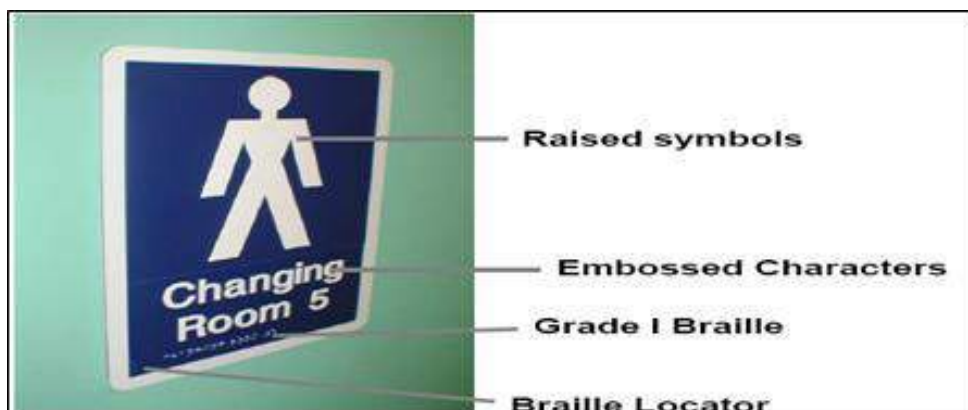

Figure 6-7: Signage with embossed letters and Pictogram

6.4.1 Colour Contrast Signs

Contrasting colours should be used to differentiate the figures from the background on the signboard. The commonly employed colours are white for the figure and blue for the background. The colours of signboard should also contrast with the surrounding surface so as to be clearly distinguishable. The colour combinations red/green and yellow/blue should not be used in order to avoid confusing persons who are colour blind. Avoid using shades of the same colour in the sign and avoid using same colours as safety signs. The recommended colour contrast between the letters and background is a 70 point LRV difference.

Information from signs can be conveyed by the colour of lettering and brightness differentials between the letter and background colours. Safety signs use primarily red, yellow and green as information colours. For other signs it is preferable to use Blue and White Colours.

Contrast

Visual contrast is defined as the difference in Light Reflectance Value (LRV) between two contiguous surfaces. Light Reflectance Value is measure on a scale of 0 to 100 where 0 equals black and there is total light absorption and white = 100 and there is total light reflection. In most circumstances, a difference in these values of 30% is considered adequate. However, research suggests that signs are more legible for the visually impaired when characters contrast with their background by at least 70%.

A simple formula for Visual Contrast is given below:

$$\text{Visual Contrast} = [(B1-B2)/B1] \times 100 \%$$

where B1 is LRV of the lighter area

and B2 is LRV of the darker area

6.4.1.1 Basic principles for Colour Contrast:

- Text should contrast with sign background
- Sign should contrast with environment
- Light levels (measured in Lux)
- 70% contrast between wall and sign panel
- Avoid shades of colours
- Avoid using same colours as safety signs
- Maximum 5 colours
- Non-reflective surface

6.4.1.2 Schedule of Colour Contrast for Signs

- Schedule for colour contrast with sign background is given in Table 6-1.

Table 6-1: Typical Schedule of Colour Contrast for Signs

Background	Sign Board	Legend
Red Brick or Dark Stone	White	Black, dark green or dark blue
Light brick or light stone	Black/dark	White or Yellow
Whitewashed walls	Black/Dark	White/Yellow
Green Vegetation	White	Black, dark green or dark blue
Back-lit sign	Black	White or yellow



Figure 6-8: Signage- Preferred colour contrast

6.4.2 Character, Content and Layout

6.4.2.1 Signage Typeface and Style

Sign typefaces must be standard, legible and clearly discernible. Only Sans serif family of fonts are recommended such as Arial, Helvetica Medium, Futura etc. Usage of too many type sizes on any one sign should be avoided. Also italics or script texts should be avoided.



Figure 6-9: Typeface and Style

6.4.2.2 Basic principles

- Sans serif font (A sans serif font is a family of fonts that does not have the small feature called “serifs” at the end of strokes. Pixilation makes sans-serif fonts appear cleaner than serif fonts and they are therefore widely used for

on-screen text. Common sans serif fonts include: Microsoft Arial, Arial Black, Trebuchet MS, Verdana, etc. Be aware that in some sans-serif fonts capital “I” and lower case “l” will appear exactly identical (e.g. Arial). Thus use them with caution.)

- Should be mix of Upper and lower case
- Should be Left justified
- Should be Tactile embossed with Braille
- Minimal use of bold
- Consistent font stem widths
- Avoid italics, condensed text, light stems

6.4.2.3 Upper and Lower Case Lettering

- Signs are more effective when they employ both upper and lower case lettering. This is because people recognize ‘word shapes’ rather than literally reading every letter to build up the word and must be left justified.
- The height and boldness of the lettering can be used to indicate the nature of the information that the sign imparts.

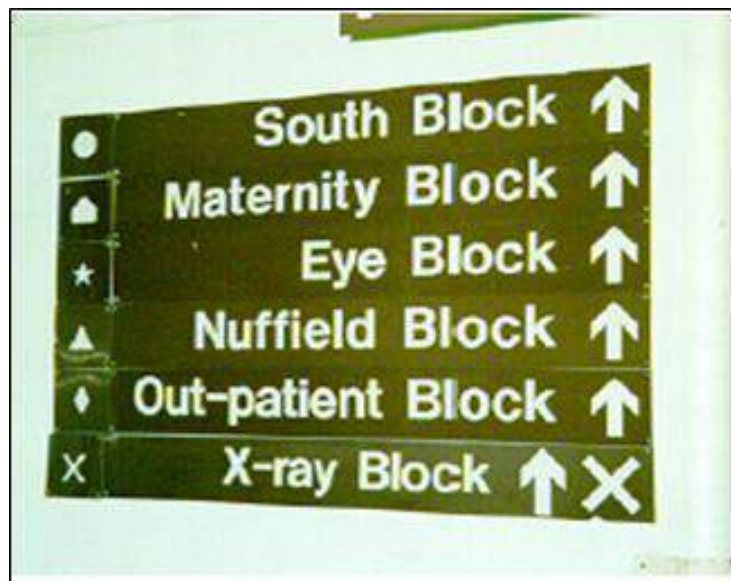

Figure 6-10: Signage in upper and lower case

6.4.2.4 Line spacing

The spacing between lines should be 50% of the line height. The diagram below indicates what is meant by “line height” and from where the measurement of 50% should be taken.

A style should be chosen because based on a character width-to-height ratio within 3:5 and 1:1 (Figure 6-11) and the stroke width-to-height ratio between 1:5 and 1:10. It should be consistent for each sign.

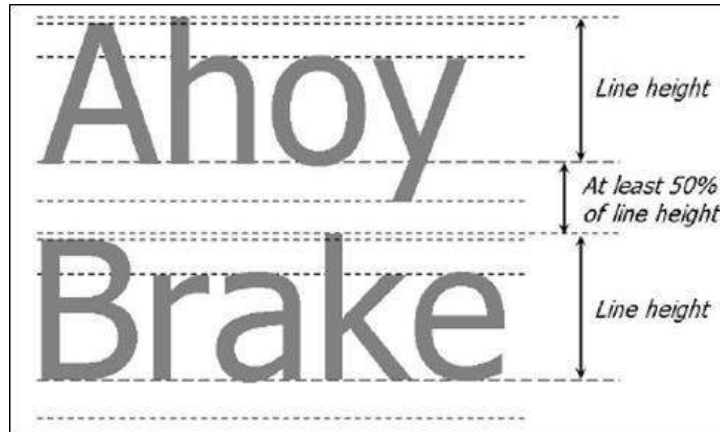

Figure 6-11: Spacing between lines

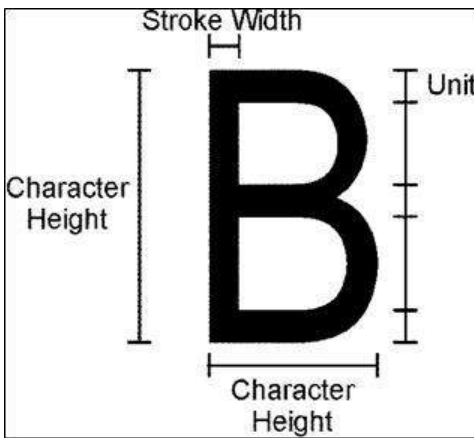

Figure 6-12: Character Proportion

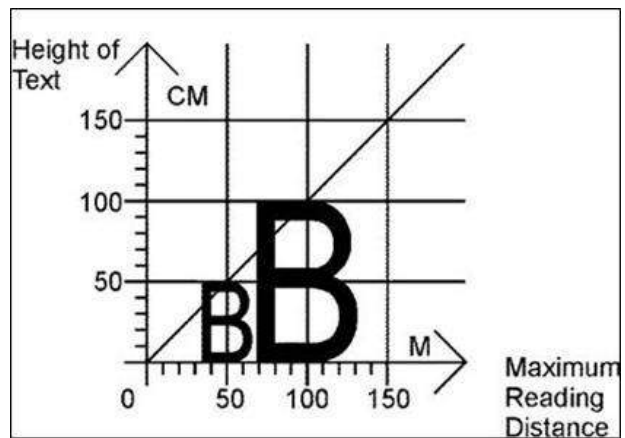

Figure 6-13: Character Height

6.4.2.5 Pictograms

- Ideally any signage should incorporate a combination of lettering and symbols.
- This will empower persons with Autism, intellectual disabilities and multiple disabilities as well as those with language barriers.



Figure 6-14: Access symbols



Figure 6-15: Information signage

6.4.3 Positioning the Signage

- Signs should be located where they are clearly visible. A person with low vision may be able to read a sign if they can approach the sign for close up viewing. Wall-mounted signs that contain detailed information; timetables, maps or diagrams, should be centered around 1400mm from the ground, with the bottom edge not less than 900mm from the finished floor level and the top edge up to 1800mm from the finished floor level.(Figure 6-11)
- Braille and tactile signage should be placed at a height between 900 mm to 1500 mm (ideal location at 1050 mm) above the finished floor level
- Duplicating detailed signs and instructions, especially safety notices, should be located at high and low levels, i.e. at 1600 to 1700mm and at 1000 to 1100mm to allow convenient close viewing by wheelchair users.
- Signs should be positioned in way that the reader does not obstruct circulation paths. Position projecting or ceiling suspended signs above head height at 2300mm from floor level. Although it is important that the sign does not create a head height obstacle, it is equally important that the size of the lettering increase in proportion to the distance from the reader.

6.4.3.1 Sign Location inside the Building

- Signs should be located where they are clearly visible (Figure 6-16).

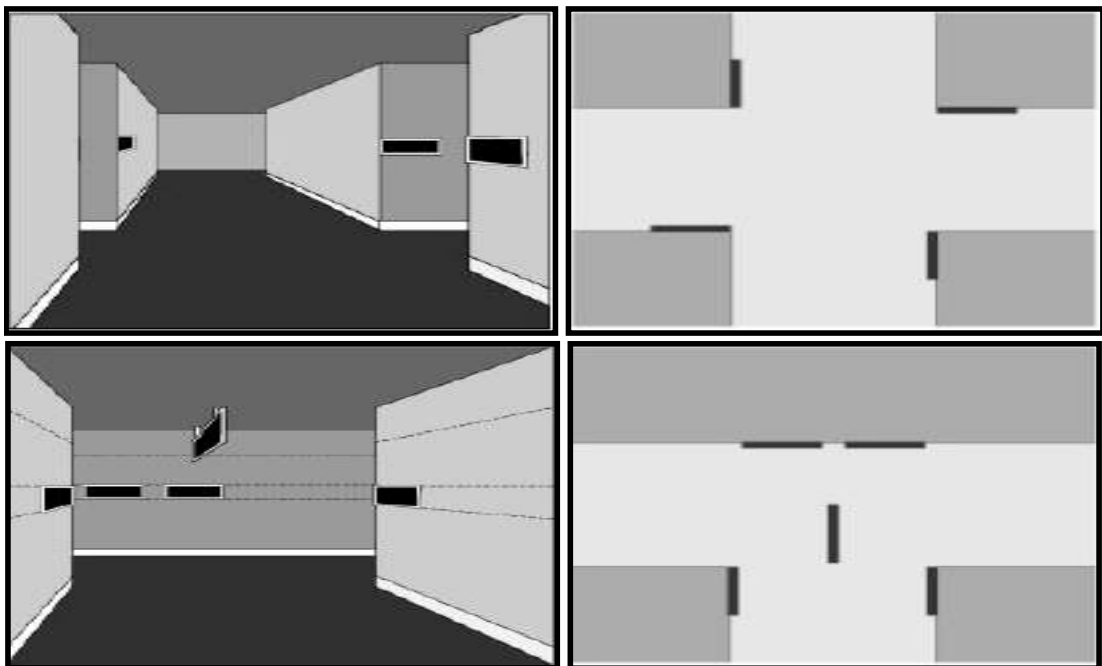

Figure 6-16: Preferred location of signages

- Top of building directory signage, building direction signage and bulletin board signs should be 1800mm from the finished floor level.
- Room number and identification signage to be at 1400mm from the finished floor level to bottom of the sign, and 50mm from the door frame (Figure 6-17). In case of tile wall, the closest horizontal joint should be used.

- Detailed signs and instructions, especially safety notices, should be located at both high and low levels, i.e. at 1600-1700mm and at 1000-1100mm to allow convenient close viewing by wheelchair users.

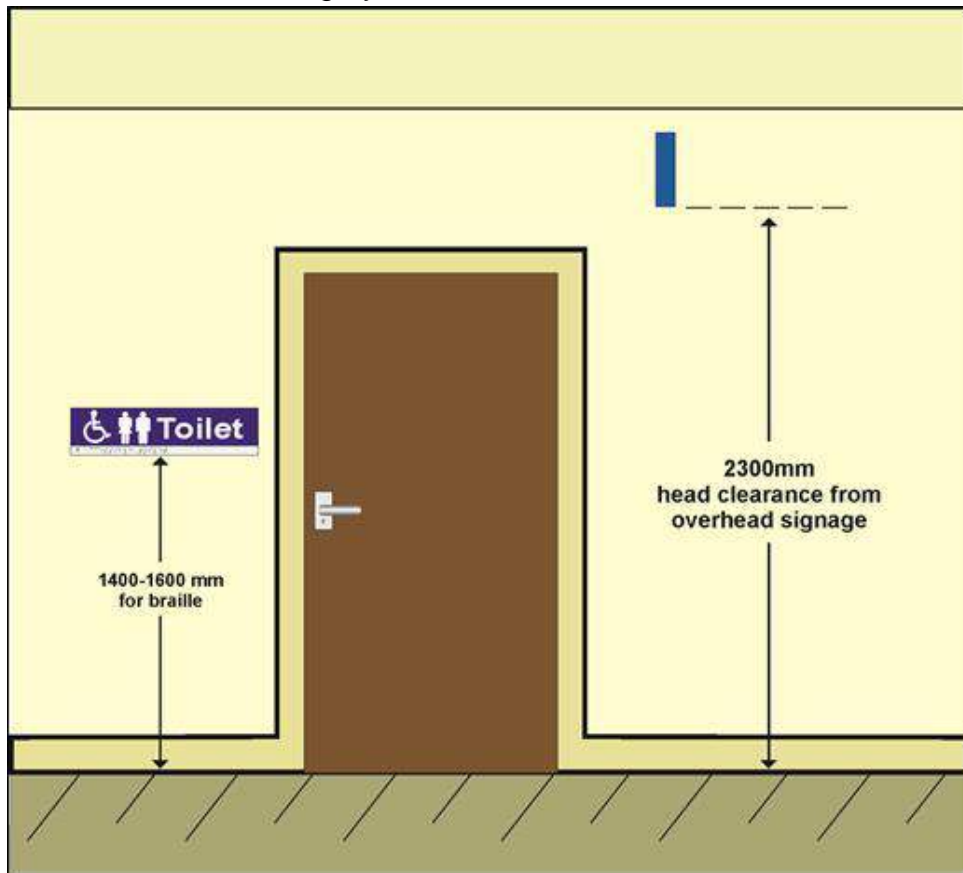

Figure 6-17: Height and placement of signages

6.4.4 Viewing Distances for signage

- Long distance signage include fascia signs, external location, external direction, house numbers
- Medium range includes location + direction, identification signage
- Close range would include room signs, directories, wall mounted information etc.

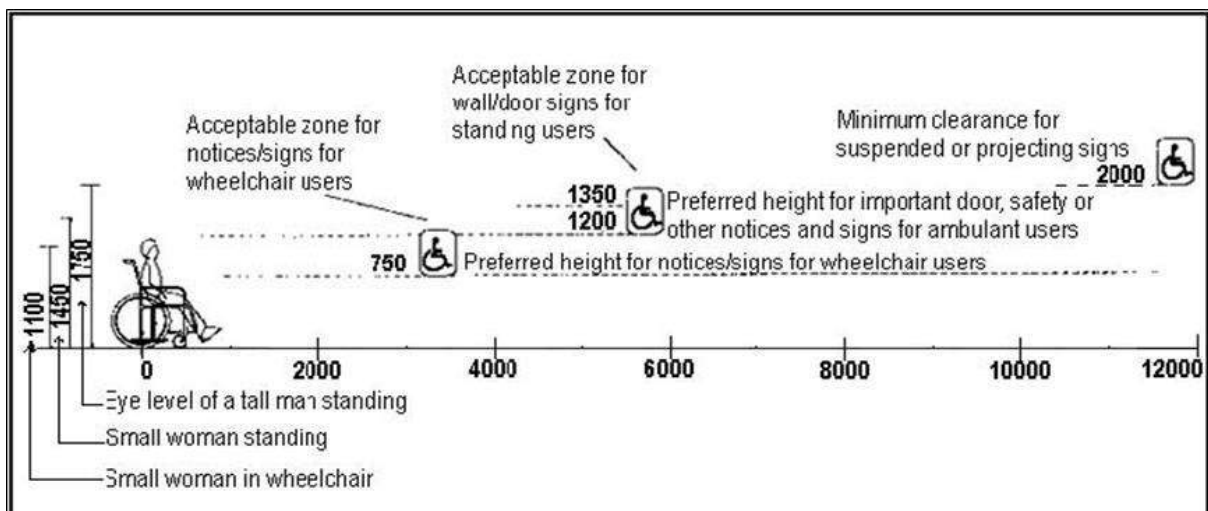

Figure 6-18: Viewing distance for signages

6.4.4.1 Size of Signage

- The width for signage should be standardized. Viewing distance and size of signage is given in Table 6-2

Table 6-2: Size of Signage

Viewing Distance	Size of signage
Up to 7 meters	60 mm x 60 mm
7 meters – 8 meters	100mm x 100 mm
Exceeding 8 meters	200 mm x 200 mm to 450 mm x 450 mm

6.4.4.2 Size of Letters in Signage

In Table 6-3 viewing distance and height of letters are given.

Table 6-3: Size of Letters in Signage

Viewing Distance	Height of letters
2 - 3 meters	15 mm
6 meters	20 mm
8 meters	25 mm
12 meters	40 mm
15 meters	50 mm
25 meters	80 mm
35 meters	100 mm
40 meters	130 mm
50 meters	150 mm

6.4.5 Lighting/ Signage Illumination

Signs should be well and evenly lit with uniform lighting over the surface of the sign of between 100 and 300 lux. Minimum acceptable level of lighting for directional signage, maps and text panel is 200 lux.

Lux: Lux is the standard unit of luminance. It is used as a measure of perceived intensity of light. Below are a number of examples of what a variety of lux would correspond to in every day terms:

Illuminance	Example
1 lux	Moonlight
400 lux	A brightly lit office
400 lux	Sunrise or sunset on a clear day
1000 lux	Typical TV studio lighting
32000 lux	Sunlight on an average day (min)
100000 lux	Sunlight on an average day (max)

6.4.6 Signage material

- Signage Material should be non-reflective, preferably matt finish. It should have non-glary and non-glossy surface. Natural and artificial light should be such so as not to produce glare on the signage surface.
- The material of all signage should be chosen so as to reduce wear and tear and possible damage by vandalism and at the same time easy to maintain. Some suggested materials for signage are wood, acrylic, Aluminum Composite Panel (ACP).

6.4.7 Alternative formats-tactile signs

Common alternative formats can be used to assist people with visual impairments who are best able to interpret information through hearing or touch. Embossed letters, raised pictograms and raised arrows are tactile features that can be incorporated into signs, which can be particularly helpful to persons with visual impairment. It is important to provide both Braille and audio inputs to signage for persons with visual impairments. Providing only Braille does not make the signage accessible, as a large number may not use Braille.



Figure 6-20: Embossed letters – tactile signs



Figure 6-19: Braille locator -tactile signs

6.4.7.1 Braille specification

A system of touch reading for people who are blind or vision impaired that employs raised dots, evenly arranged in quadrangular letter spaces or cells. Braille symbols are formed within units of space known as Braille cells. A full Braille cell consists of six raised dots arranged in two parallel rows each having three dots (Figure 6-21). The dot positions are identified by numbers from one through six. Sixty-four combinations are possible using one or more of these six dots. A single cell can be used to represent an alphabet letter, number, punctuation mark, or a whole word.

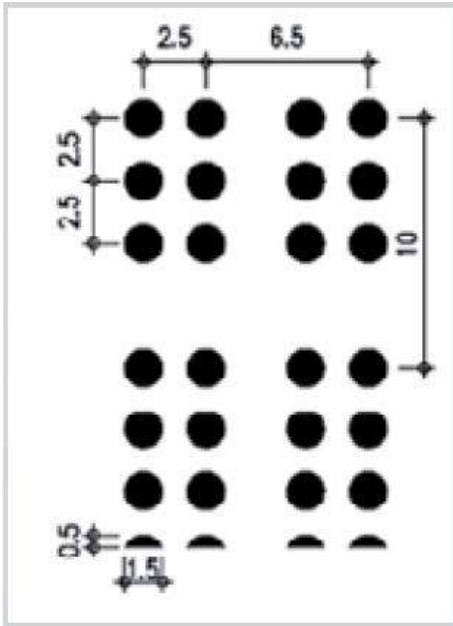

Dot Spacing:	2.5 mm	Character Spacing:	6.5 mm
Dot Height:	0.5 mm	Line Spacing:	10.0 mm
Dot Base Diameter:	1.5 mm		

Figure 6-21: Braille specifications

6.4.7.2 Maps & Models

- A map or model can be particularly helpful, especially to visually impaired people who may be unable to read signs, and to people with hearing impairments who may not be able to understand verbal directions.
- A tactile map or model is a useful way of providing information to visually impaired people and people with hearing impairments who wish to navigate around a building.



Figure 6-22: Tactile map



Figure 6-23: Tactile and Audio map

6.4.7.3 Audio Signs/Audio information

- Audible announcements are helpful to most people but particularly to those with visual impairment.
- It is essential that there is a significant difference between the level of background noise and the level of the signal or announcement.
- The higher the signal to noise ratio (the difference in decibels dB. between signal and ambient) the better for communication.
- People with hearing impairment require at least a +5dB S/N ratio.
- In environments that are noisy, any spoken information should be repeated at least once.
- Audible alarm systems should operate at least 15dB over the prevailing sound level, with a maximum of 120dB

6.4.7.4 Audio visual signage

Audio signs – which can play a recorded message when touched or activated by a person’s movement or presence. Information can be provided in various formats, languages or methods of transmission. For e.g. Tactile map at Hong Kong Wetland Park (Figure 6-22& 6-23) also has an option of audio output in local and English language.



Figure 6-25: Talking signs



Figure 6-24: Speaker and buttons in talking signs

6.4.7.5 International Symbol of Accessibility

The International Symbol of Accessibility (Figure 6-27) must be displayed at all accessible entrances. If an entrance is not accessible, directions to an accessible route, including the symbol, must be provided. Similar guidelines refer to elevators, evacuation and refuge areas, restrooms and bathing facilities. Symbols of accessibility are also required to identify volume control telephones, text telephones, and assistive listening systems.



Figure 6-27: International Symbol of Accessibility

Colour to be Navy Blue with White lettering, Symbols and Border and size to be 200mm x 200mm square with 1.25mm border. The specific pictograms shown in Figure 6-15, are required in certain signage situations



Figure 6-28: Signage for accessible Access



Figure 6-29: Signage for Accessible Facilities



Figure 6-30: Signage for Persons with Vision Impairment



Figure 6-31: Pictograms for Accessible Facilities

7 LEVEL CHANGES

7.1 Kerb Ramps

7.1.1 Kerb ramps

- are provided where the vertical rise is less than 150 mm;
- should have a slip-resistant surface;
- should be designed not to allow water accumulating on the walking surface;
- do not require handrails;
- should not project into the road surface;
- should be located or protected to prevent obstruction by parked vehicles; and
- should be free from any obstruction such as signposts, traffic lights, etc.
- should not be used if they project in

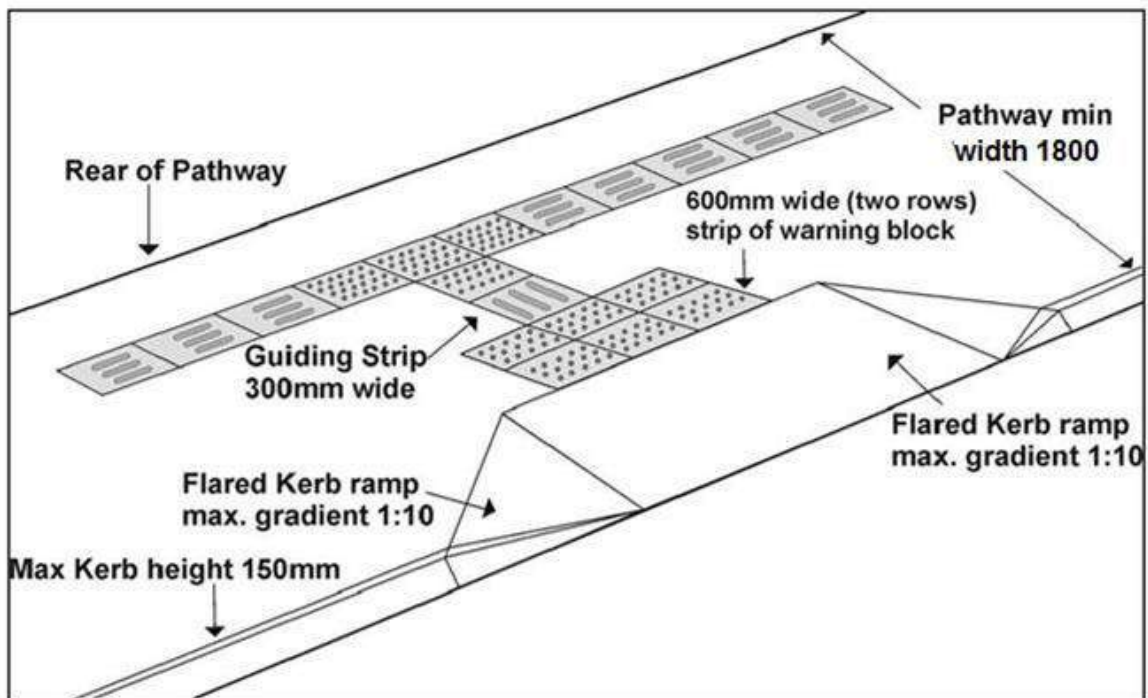

Figure 7-1: Kerb ramp detail

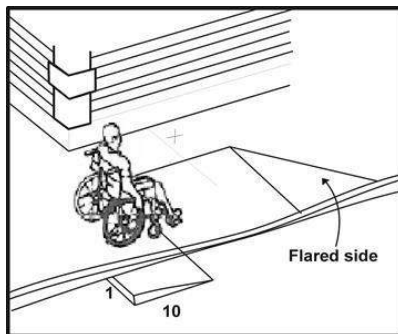

Figure 7-2: Kerb extension at street intersection

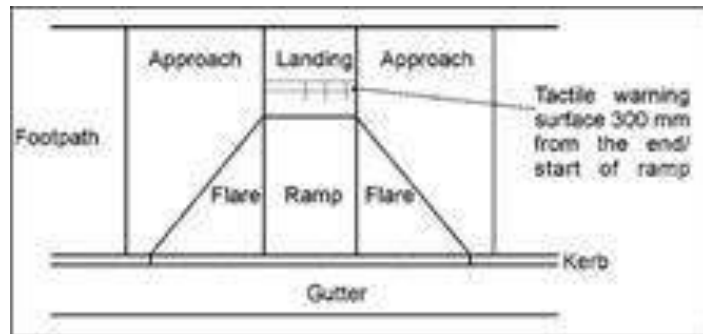

Figure 7-3: Typical kerb ramp requirements

7.1.2 Gradient

The gradient of a kerb ramp should not be steeper than 1:12; the flared sides should not be more than 1:10.

7.1.3 Width

The width should not be less than 900mm min.

7.1.4 Flared Sides

- Kerb ramps should have flared sides where pedestrians are likely to walk across them as shown in the figure 7-4; and
- The gradient of the flared side should not be steeper than 1:10.

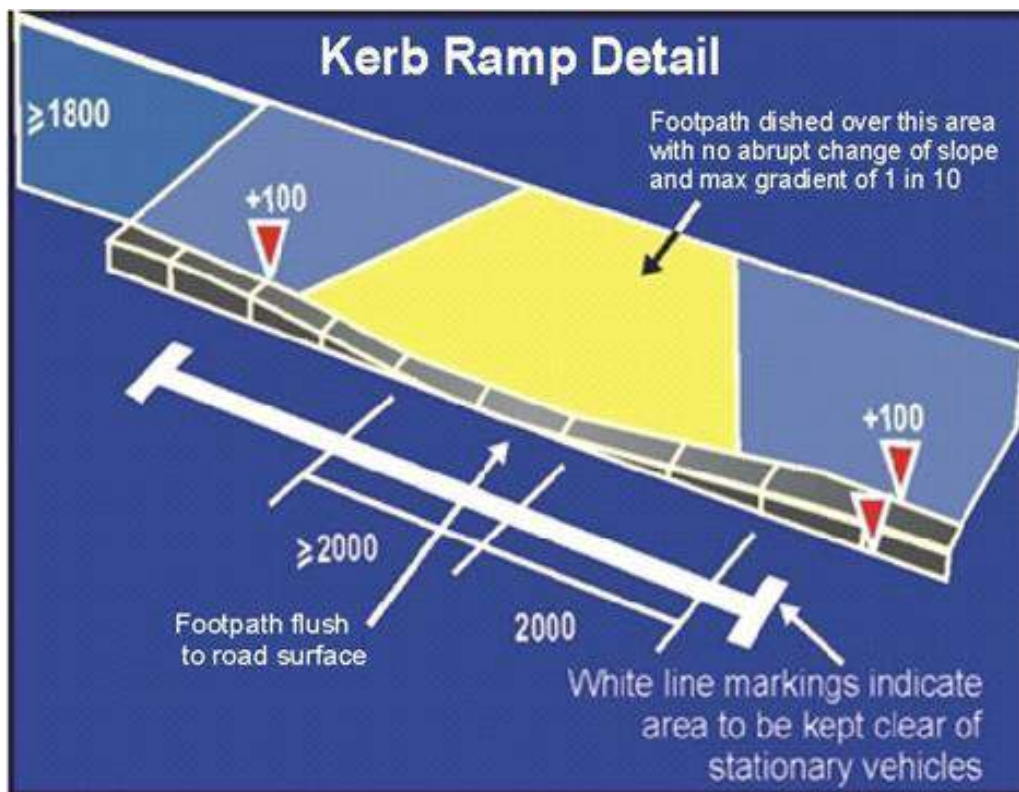

Figure 7-4: Kerb ramp detail

7.2 Ramps

7.2.1 General

- Ramps allow persons in wheelchair to move from one level to another. However, many ambulant Persons with Disabilities negotiate steps more easily and safely. Hence, it is preferable to provide accessibility by both steps and ramps.
- Where the horizontal run of the approach ramp exceeds 9000 mm length, an alternative stepped approach as described in Section 7.2, in addition to the ramp approach, should be provided for people with ambulatory disabilities.
- Where there is a large change in elevation that requires multiple ramps and landing combination, other solutions such as elevators should be considered

- Single row of tactile warning blocks should be placed at beginning and end of each ramp at also at the beginning and end of each run.

7.2.2 Gradient

It should be noted that the gradient should be constant between landings. The recommended gradients for ramps are given in the Table 7-1.

Table 7-1: Minimum specifications for Ramps

Level difference	Minimum gradient of Ramp	Ramp Width	Handrail on both sides	Comments
≥ 150 mm ≤ 300 mm	1:12	1200 mm	√	
≥ 300 mm ≤ 750 mm	1:12	1500 mm	√	Landings every 5 meters of ramp run.
≥ 750 mm ≤ 3000mm	1:15	1800 mm	√	Landings every 9 meters of ramp run.
≥ 3000 mm	1:20	1800 mm	√	Landings every 9 meters of ramp run.

7.2.3 Width

The minimum clear width of a ramp should be 1200 mm.

7.2.4 Surface

- Ramps and landing surfaces should be slip resistant as described in the and
- Outdoor ramps and their surface should be designed to prevent water from accumulating on the walking surfaces.

7.2.5 Landings

- Ramps should have a level landing at the top and bottom of each run and also where the run changes direction as shown in the figure 7-5.
- Landings should:-
 - Be provided at regular intervals of not more than 9000 mm of every horizontal run as shown in the figure 7-5;
 - Have a level platform of not less than 1500 mm; and
 - Conform to Section 5.4.3, if served by a doorway.

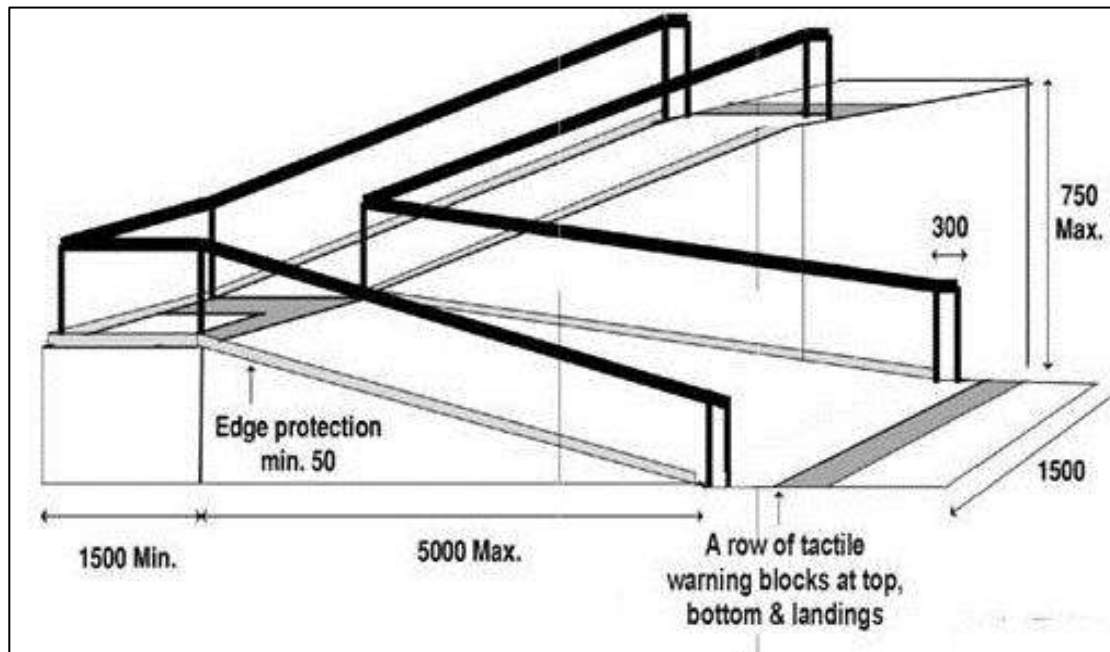

Figure 7-5: L-shape ramp with landing

7.2.6 Handrails

A ramp run with a vertical rise greater than 150 mm should have handrails that:

- are on both the sides;
- comply with Section 5.9;
- are placed at a height of between 760 mm and 900 mm above the floor level;
- handrails must be continuous on both sides & even at landings.

Handrail extensions as shown in the Figure 7-6, should:

- Extend horizontally for a distance of not less than 300 mm beyond the top and bottom of the ramp to provide support for persons who may need help to negotiate the ramp; and
- Not project into another path of travel.

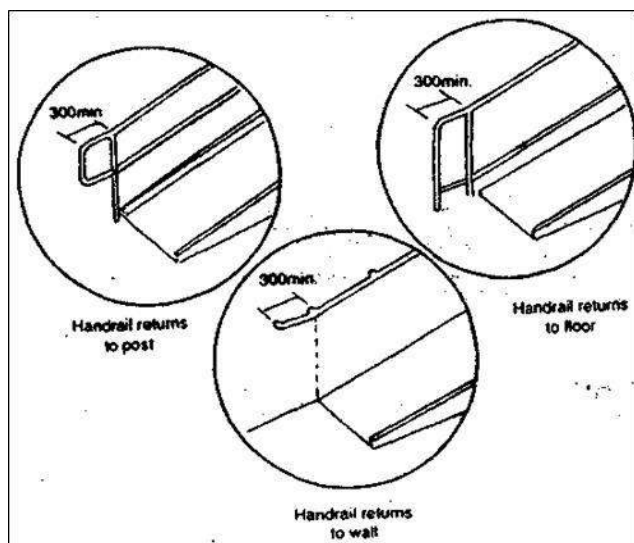

Figure 7-6: Typical handrail extensions

7.3 Stairs

- Stairs should not be the only means of moving between floors. They should be supplemented by lifts (Section 7.4) and /or ramps (Section 7.2).
- Treads should be 300 mm deep and risers not higher than 150 mm.
- There should be no more than 12 risers in one flight run.
- The stairs landing should be minimally 1200mm deep.
- The stairs should have minimum 1500mm clear width.
- Steps should be of a consistent height and depth throughout the staircase.
- Projecting nosing and open stairs should not be provided to minimize the risk of stumbling. Also, spiral stairs should be avoided.
- Handrail for stairs should: -
 - Comply with Section 5.9.3;
 - Extend not less than 300 mm beyond the top and bottom step (Figure 7-6 and 7-7).

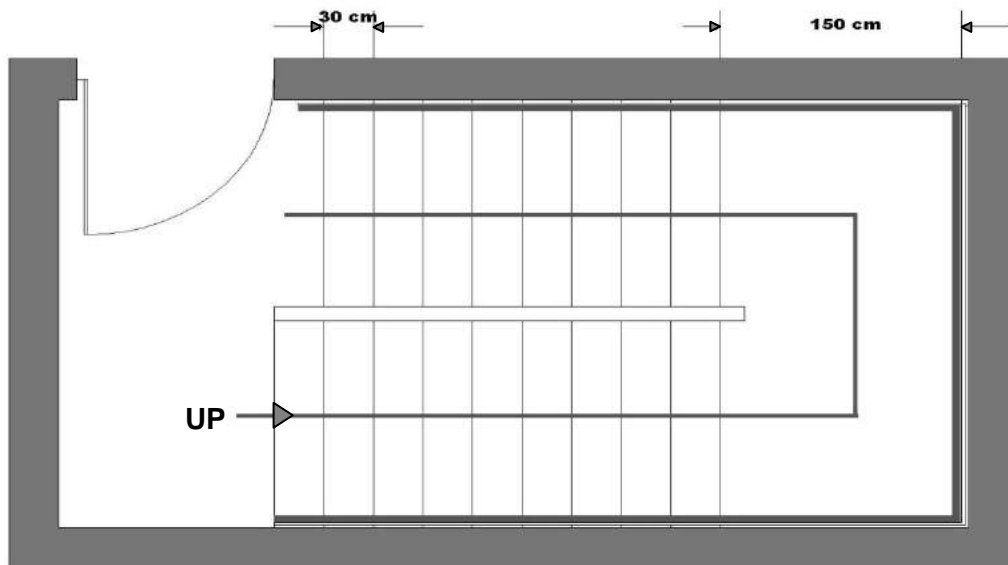

Figure 7-7: Continuous and extended handrail

Warning blocks should be installed 300 mm before the beginning and 300 mm after the end of each flight of steps (Figure 7-8 and 7-9) to aid people with visual impairments complying with Section 5.1.3



Figure 7-9: Warning blocks at landings



Figure 7-8: Placement of warning blocks for steps

- There should be colour contrast between landings, and the steps.
- Step edges must contrast in colour to the risers and the treads. Contrast colour bands 50 mm wide should be provided on edge of the tread (Figure 7-10).

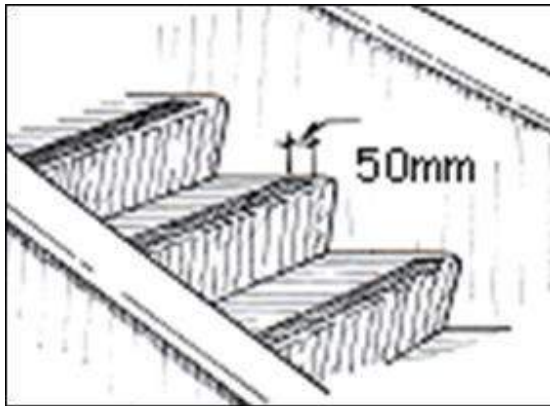

Figure 7-10: Colour contrast for step edges

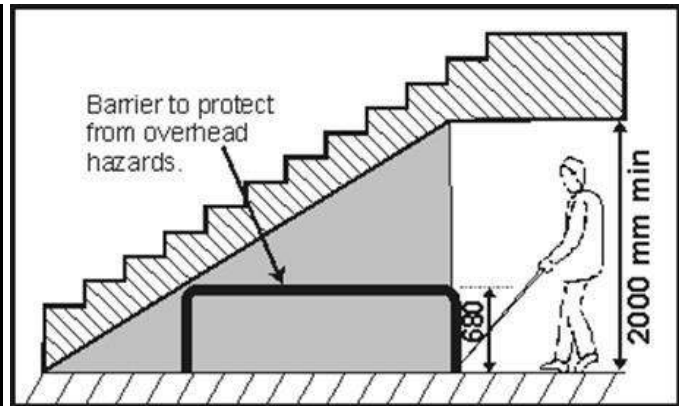

Figure 7-11: Guard rail under soffit

7.4 Lifts

7.4.1 Lift signage

- Where lifts are provided in a building they shall be accessible to and usable by Persons with Disabilities at all levels used by the general public or staff. Lifts should be marked with the symbol of accessibility and directional signs be provided to the lifts.
- Signs indicating the location of an accessible lift should be provided in a location that is clearly visible from the building entrance (Figure 7-12). The sign should incorporate a representation of the International Symbol for Access (Section 6.4.7.5).
- A sign indicating the number of the floor should be provided on each lift landing on the wall opposite the lift. It is also recommended to install a floor directory of the main facilities and services available on the lift landing, along with an accessible emergency egress route that clearly indicates the location of nearest refuge areas for Persons with Disabilities.



Figure 7-12: Way finding signage for lift location

7.4.2 Lift Size

The minimum size of the lift should be 1500 mm wide by 1500mm deep (Figure 7-13); wherever possible, 13 passenger lift to be provided, which allows easy maneuverability of wheelchair user.

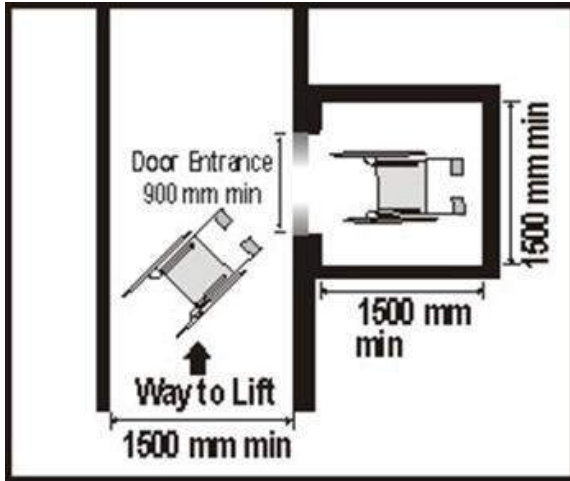

Figure 7-13: Size of lift

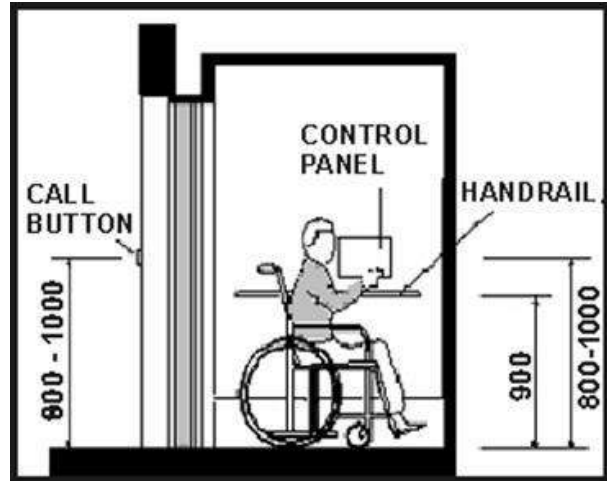

Figure 7-14: Placement of lift accessories

7.4.3 Door

- The lift door should have a clear opening of not less than 900 mm (Section 5.7) and contrasting in colour from the adjoining wall.
- There should be no difference in level between the lift door and the floor surface at each level. The gap between the lift door and building floor should not be more than 12 mm.
- Time of closing of an automatic door should be more than 5 seconds and the closing speed should not exceed 0.25 meters per second.

7.4.4 Call Button

- The call button located outside the lift should:
 - Have a clear floor space of at least 900 mm x 1200 mm with no obstruction placed to prevent a wheelchair user from reaching the call button; and
 - Be installed at a height between 800 mm and 1000 mm (Figure 7-14).

7.4.5 Control Panel

The control panel should:

- Have a clear floor space of at least 900 mm x 1200 mm with no obstruction placed to prevent a wheelchair user from reaching it;
- Be placed at a height of between 800 mm and 1000 mm from the floor level (Figure 7-14); and
- Have buttons with Braille/ raised letters and in sharp contrast from the background to aid people with visual impairments (Figure 7-15).

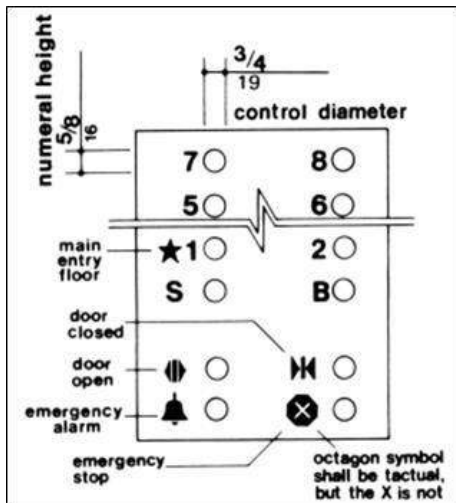

Figure 7-16: Layout of lift control panel

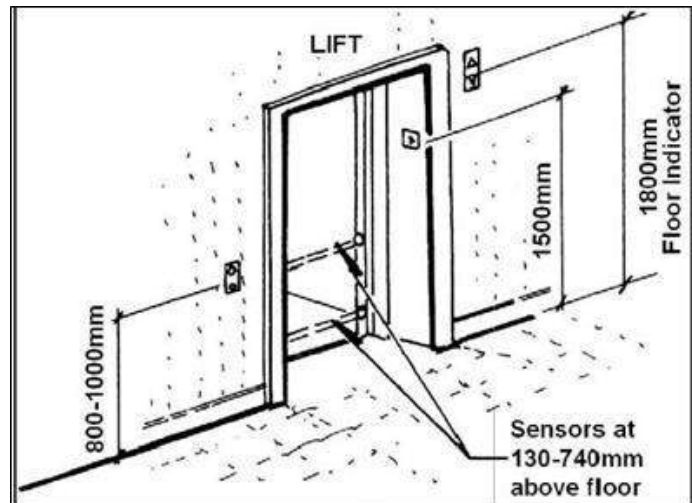

Figure 7-15: Specifications of lift controls

7.4.6 Grab Bars

Grab bars should:

- Comply with Section 7.2.6;
- Be placed at a height of 900 mm from the floor level (Figure 7-16); and
- Be fixed on both sides and at the rear of the lift.

7.4.7 Audio and Visual Indicators

- The lift should have a voice announcement system along with a visual display to indicate the floor level and also the information that the door of the cage is open or closed for entrance or exit
- The announcement system should be clearly audible i.e. the announcement should be 50 decibel.

7.4.8 Other facilities

- The use of visually and acoustically reflective wall surfaces should be minimized within the lift car as visual reflections can cause discomfort and affect the visual acuity of people with visual impairments.
- The floor of the lift car should be slip resistant and have similar frictional qualities to the floor of the lift landing to decrease the risk of stumbling.
- The provision of a mirror on the wall of the lift car opposite the lift door is a positive aid to navigation for wheelchair users. It allows the wheelchair user to see if anyone is behind them and also to see the floor indicator panel. The mirror should not extend below 900 mm from the lift floor to avoid confusing people with impaired sight.
- The emergency communication system should be coupled with an induction loop system installed all around the lift. Telephone units, where provided, should have an inbuilt inductive coupler to assist persons using hearing aids.

7.5 Wheelchair Stair-lift and Platform Lift

Where it is impracticable to provide a lift or a ramp, a wheelchair stair-lift or platform lift should be considered as a reasonable alternative for vertical circulation within the building.

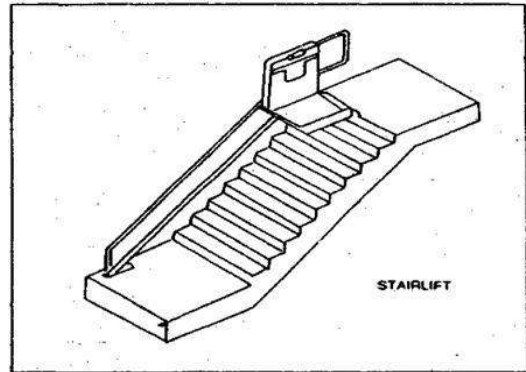

Figure 7-17: Stair lift

7.5.1 General

- Platform lifts are special passenger elevating devices for people with disabilities.
- Platform lifts can have either a vertical or an inclined movement.

7.5.1.1 Vertical Movement Platform Lifts

- For maximum level changes of 2500 mm, vertical movement platform lifts may be installed.
- For level changes of more than 1200 mm, the lift should be placed in a closed structure with doors at different accessible levels.
- Vertical platform lifts can have a variety of openings for entry and exit.
- Minimum size should be 1200 X 1000 mm.

7.5.1.2 Inclined movement platform lifts

- Inclined movement platform lifts consist of three elements a railing, an electric generator and a moving platform or seat.
- Inclined movement platform lift can be installed along the stair wall as long as they do not obstruct the required width of the exit. The seat or platform can be folded when not in use.



Figure 7-18: Platform chair lift and platform lift

- The Minimum width of the stairs should be 900 mm to allow the installation of the lift. Platform lifts can be installed on all types of stairs including switch back stairs i.e. those with a rotation of 180 and spiral staircases
- Inclined movement platform lifts are usually used to connect one or more floors or to overcome split levels in existing buildings

7.5.1.3 Lift Size

- The minimum width of the platform lift should be 1050 mm and the minimum length should be 1250 mm.

8 ACCESS TO TOILET FACILITY

8.1 General

- Signage at accessible toilet entrance should be clearly visible and should comply with the International Symbol of Accessibility complying with Section 6.4.7.5.
- Where urinals are provided, at least one should comply with Section 8.4 and 8.12, to cater to the ambulant disabled.

8.2 Unisex Accessible Toilets (multi-use)

- Unisex accessible toilet allows Persons with Disabilities to be assisted by carers of the same or opposite gender. In all public buildings, one unisex accessible toilet should be provided in each toilet block on each floor. Apart from this all toilet blocks must have one cubicle suitable for use by persons with ambulatory disabilities.
- The unisex toilet should have: -
 - Minimum internal dimensions of 2200 X 2000 mm minimum (Figure 8-2);
 - The layout of the fixtures in the toilet should be such that there is a clear maneuvering space of 1800mm x 1800mm in front of the water closet and wash basin in the accessible toilet unit (Figure 8-1);
 - All fixtures and utilities should provide a clear space of 900mm x 1200 mm for wheelchair users to access them;
 - Have clear space of not less than 900 mm wide next to the water closet;
 - Be equipped with a door complying with Section 8.5;
 - Have a water closet complying with Section 8.6;
 - Have grab bars complying with Section 8.7;
 - Have a wash basin complying with Section 8.8;
 - Have essential washroom accessories complying with Section 8.9;
 - Have the toilet roll dispenser and hand water faucet mounted below the grab bars and at not more than 300 mm from the front edge of the seat and at a height between 50 mm and 200 mm from the top of the water closet seat;
 - Be equipped with a cloth hook mounted on a side wall not more than 1200 mm from the floor and projecting not more than 40 mm from the wall; and
 - Where possible, be equipped with a shelf of dimensions 400 mm x 200 mm fixed at a height of between 900 mm and 1000 mm from the floor.

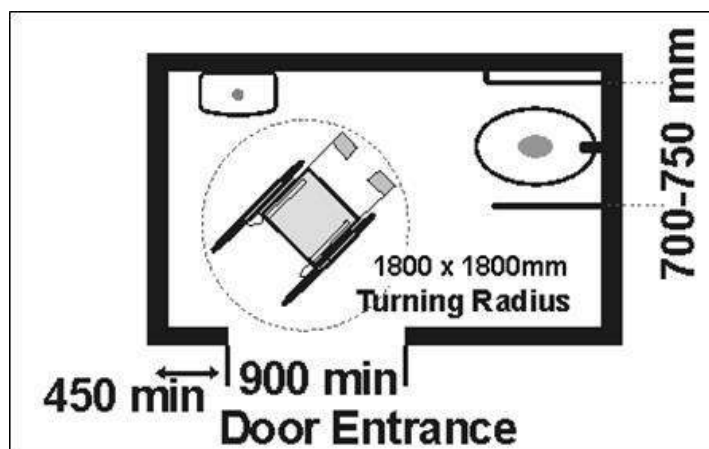

Figure 8-1: Wheelchair maneuvering space in toilet

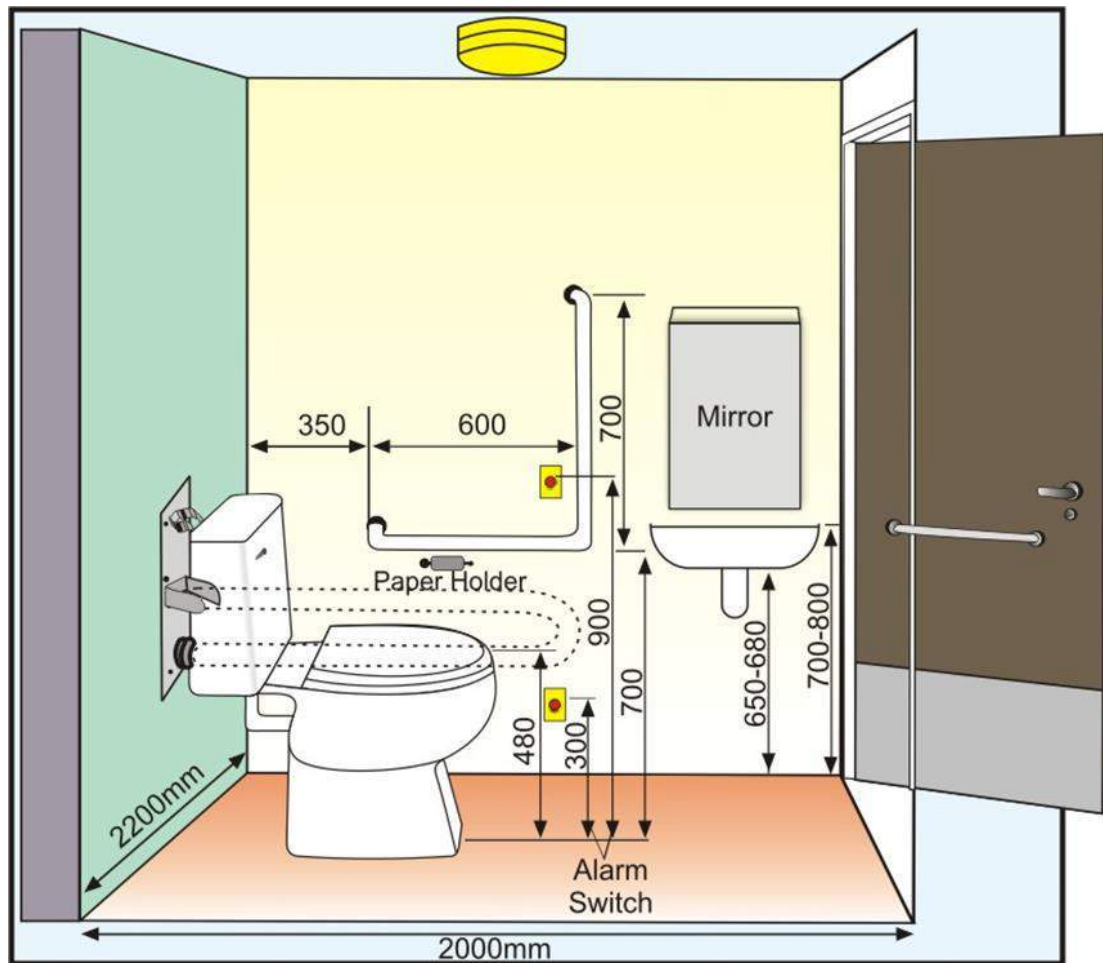

Figure 8-2: Layout plan of unisex accessible toilet

8.3 Toilet Cubicle for Wheelchair Users

Where a toilet cubicle for the wheelchair user is provided, it should conform to the dimensions as given in Section 8.2.

8.4 Toilet cubicle for Ambulatory Disabled

In a set of toilets (for ladies or for gents), there shall be one WC for the use of the ambulant disabled persons as per Figure 8-3 and 8-4.

8.5 Toilet Doors

8.5.1 Essential requirements for toilet door

- The toilet door should be either an outward opening door or two-way opening door or a sliding type and should provide a clear opening width of at least 900 mm (Section 5.7).
- Be provided with a horizontal pull-bar, at least 600 mm long, on the inside of the door, located so that it is 130 mm from the hinged side of the door and at a height of 1000 mm.
- Be capable of being locked from the inside by a device that is operable by one hand, activated by a force not more than 22N and which does not require fine finger control, tight grasping, pinching or twisting of the wrist.

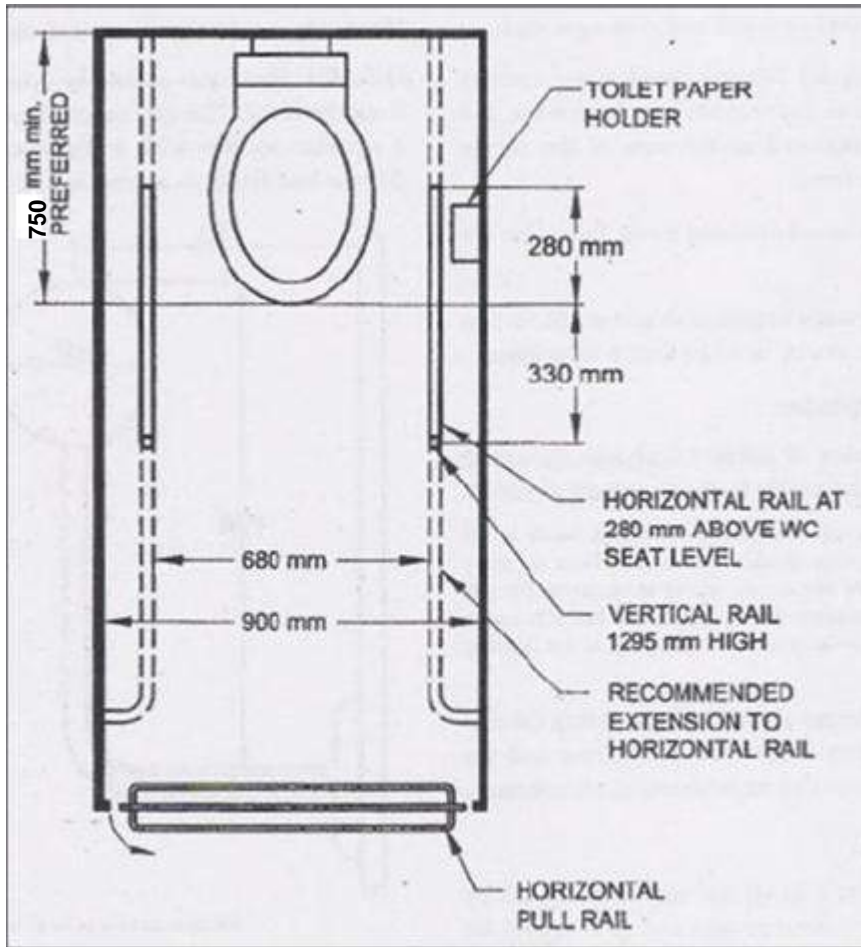

Figure 8-3: Suggested Plan WC Compartment for the Ambulant Disabled

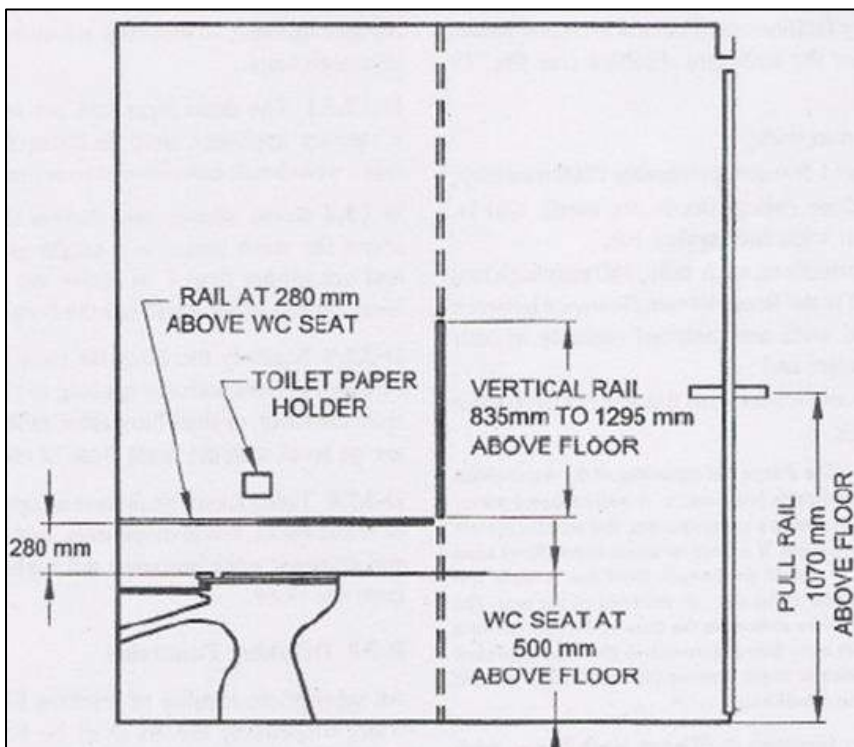

Figure 8-4: WC Compartment for the Ambulant Disabled

8.6 Water Closet

- Be located between 460 mm to 480 mm from the centreline of the water closet to the adjacent wall;
- It should have a clear dimension of 750 mm from the front edge of the water closet to the rear wall to facilitate side transfer;
- The top of the water closet seat should be 450 to 480 mm from the floor as shown in the figure 8-2; when the water closet does not have the required height, the necessary height may be obtained by providing a circular base under the water closet. The base so provided must not protrude beyond the circumference of the base of the water closet;
- There should be an adequate clear floor space of at least 1350 mm depth and 900 mm width, both in front and on the transfer side, adjacent to the water closet;
- Have a suitable back support to reduce the chance of imbalance or injury caused by leaning against exposed valves or pipes;
- Preferably be of wall-hung or corbel type as it provides additional space at the toe level;
- Where water cistern is used, the cover should be securely attached;
- The flush control should either be lever type or automatic, and located on the transfer side of the water closet. The flush control should not be located more than 1000 mm from the floor; and
- Where more than one accessible toilet is provided, a left and right hand transfer option should be made available.

8.7 Water Closet Grab Bars

- Water closets should be provided with grab bars, be mounted at a height between 200 mm and 250 mm from the water closet seat;
- One L-shape grab bar: 600mm long horizontal and 700mm long vertical should be mounted on the side wall closest to the water closet (Figure 8-6);
- A hinged type horizontal grab bar should be installed adjacent to the water closet; at a distance of 320mm from the centre-line of the WC, between heights of 200 mm - 250 mm from the top of the water closet seat and extending 100 to 150 mm beyond the front of the water closet.
- An emergency alarm cum call switch should be provided within easy reach on the wall near water closet at two levels: at 300mm and 900mm from the floor level to allow user to call for help in case of an emergency.

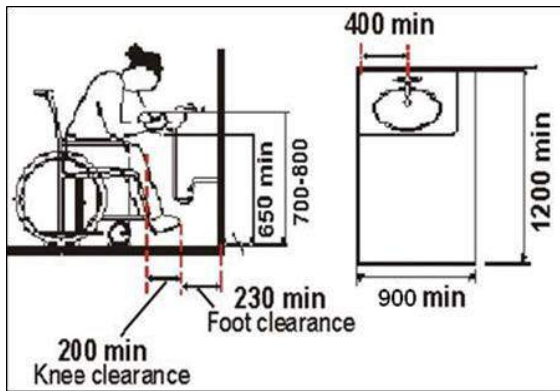

Figure 8-6: Washbasin specifications

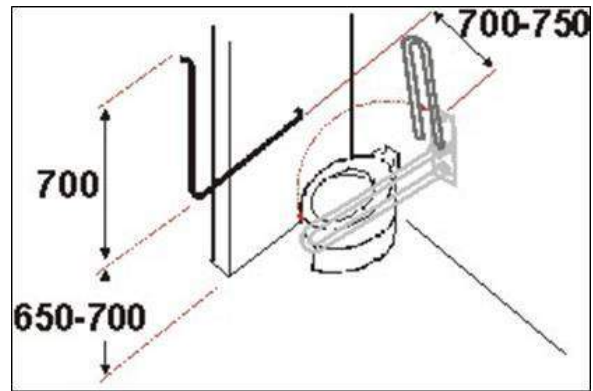

Figure 8-5: Grab bars specifications

8.8 Washroom Accessories

- Washroom accessories should comprise the following:
 - A mirror installed in a way to have the bottom edge at a height of not more than 1000 mm from the floor and mirror should be tilted at an angle of 30° for better visibility of wheelchair user
 - Towel and soap dispensers, hand dryer and waste bin positioned such that the operable parts and controls are between 800 mm and 1000 mm from the floor.
 - Accessories should be placed in close proximity to the basin, to avoid a person with wet hands wheeling a chair.

8.8.1 Additional Considerations

- There should be adequate colour and tonal contrast between the fixtures, walls and the flooring. This is to enable easy recognition by persons with visual impairments.
- There should be a visual emergency alarm in the toilet.

8.9 Urinals

- At least one of the urinals in the Gents toilets on each floor should have grab bars (Figure 8-7); installed on each side and in the front of the urinal to support ambulant Persons with Disabilities (for example, crutch users).
- The front bar is to provide chest support; the sidebars are for the user to hold on to while standing.
- Urinals shall be stall-type or wall-hung, with an elongated rim at a maximum of

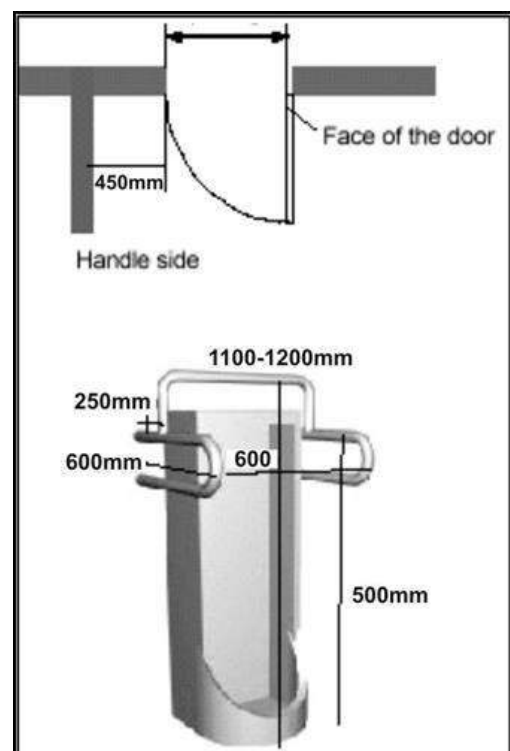

Figure 8-7: Urinal with chest support grab bar

- 430 mm above the finish floor.
- A clear floor space 760 mm by 1220 mm should be provided in front of urinals to allow forward approach. Urinal shields (that do not extend beyond the front edge of the urinal rim) may be provided with 735 mm clearance between them
- Flush controls should:
 - Comply with Section 8.6; and
 - Be located not more than 1200 mm from the floor.
- Where urinals for the ambulatory disabled are provided, they should comply with the following as illustrated in the figure 8.7.

8.10 Signage of accessible toilets

- All unisex accessible toilets should have signage (Figure 8-8).
- For individual accessible cubicles in Ladies and Gents toilets are provided signage as per Figure 8-9 should be provided.



Figure 8-8: Signage for Unisex toilet, gents and ladies toilet

- For the benefit of the persons with vision impairment, all general toilets should have male pictogram in triangle or female pictogram in circle, marked on plates with raised alphabets and Braille (Section 6.4.7.1) put on wall next to door latch. Additional signage can be provided on the door as well (Figure 8-10).
- A distinct audio sound (beeper/clapper) may be installed above the entrance door for identification of the toilets.
- For signage placement refer Figure 6.10 and 8-10.
- A clear floor space 760 mm by 1220 mm should be provided in front of urinals to allow forward approach. Urinal shields (that do not extend beyond the front edge of the urinal rim) may be provided with 735 mm clearance between them.

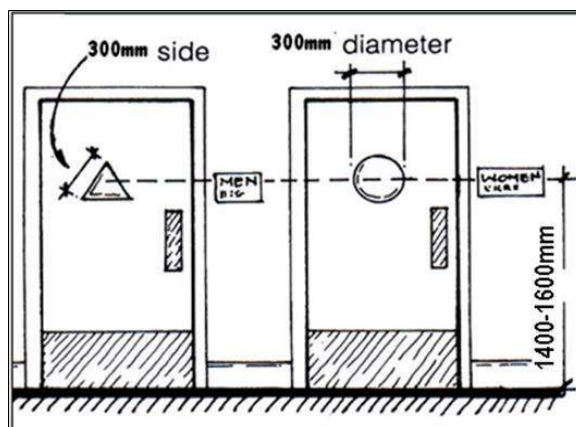

Figure 8-10: Placement of signage

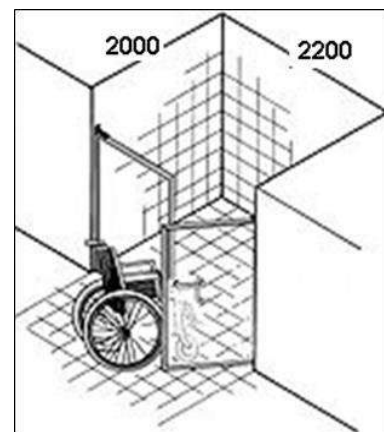

Figure 8-9: Shower Cubicle

8.11 Shower Cubicles

8.11.1 Size

- Shower cubicles should have minimum interior dimensions of 2000 mm x 2200 mm.
- A toilet cum shower room will have minimum interior dimensions of 2400mm x 2500mm
- The minimum clear floor space in front of the shower entrance should be 1350mm x 900 mm with the 1350 mm dimension parallel to the shower entrance.
- The floor of the shower should be slip-resistant.

8.11.2 Grab bars for the shower cubicle should:

- Comply with Section 8.7;
- Have one L-shaped bar or two grab bars in L-shaped configuration between 700 mm and 800 mm from the shower floor (Figure 8-12 and Section 8.7); and
- Have one grab bar at least 750 mm long installed vertically with another at least 900 mm long mounted horizontally as shown in the Photo 8-1.



Figure 8-11: Roll in shower cubicle

8.11.3 Stationary, Fittings and Accessories

- A shelf should be provided for toiletries between 400-800 mm
- All shower controls should be at a distance of 500 mm from the rear wall
- Shower controls should be installed between 750 mm to 1000 mm from the floor
- The adjustable and detachable shower head(telephone shower/ hand-held shower), with a minimally 1500 mm long hose, should be installed between 800 mm and 1200 mm from the floor.
- Where the shower head is mounted on a vertical bar, the bar should be installed so as not to obstruct the use of grab bars.
- Curbs for the roll-in shower cubicle should not be more than 10 mm high, bevelled at a slope of 1:2.
- Enclosures for the shower cubicle should not obstruct transfer from wheelchair onto shower seat.

8.11.4 Shower seat

- A wall mounted shower seat, preferably fold up kind.
- The shower seat should be positioned such that the distance between the centerline of the water closet and the adjacent wall is 450 mm to 480 mm, and the distance between front edge of the water closet and the rear wall is 650 mm. The top of the shower seat should be at a height of 450 - 480 mm from the floor.
- There should be an adequate clear floor space of at least 1350 mm depth and 900 mm width, both in front and on the transfer side, adjacent to the water closet.
- Be self-draining, non-slip and with rounded edge;
- Be on the wall nearest to the controls;
- Have a minimum dimension of 400 mm wide extending the full depth of the cubicle, less a space required for the shower curtain

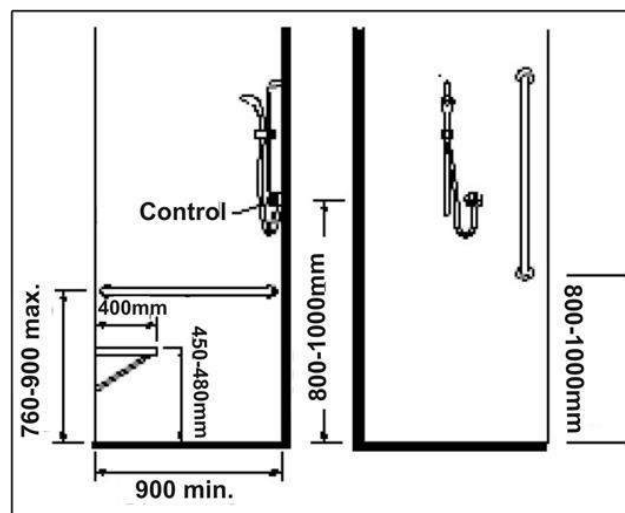

Figure 8-12: Placement of shower accessories

8.12 Public toilets

- Unisex accessible public (multi-use) toilets should be provided.
- Accessible toilets should have the international symbol of accessibility displayed outside for wheelchair access.
- The toilet door should be an outward opening door or two way opening or a sliding type and should provide a clear opening width of at least 900mm. It should have a horizontal pull-bar, at least 600mm long, on the inside of the door, located so that it is 130mm from the hinged side of the door and at a height of 1000mm.

8.13 Standardization in toilet design

Many persons with visual impairments find it convenient to use the toilets where internal dimensions, accessories and fixtures placements are standardized. A tactile layout of the toilet should be provided on the wall, near the latch side at 900mm height.

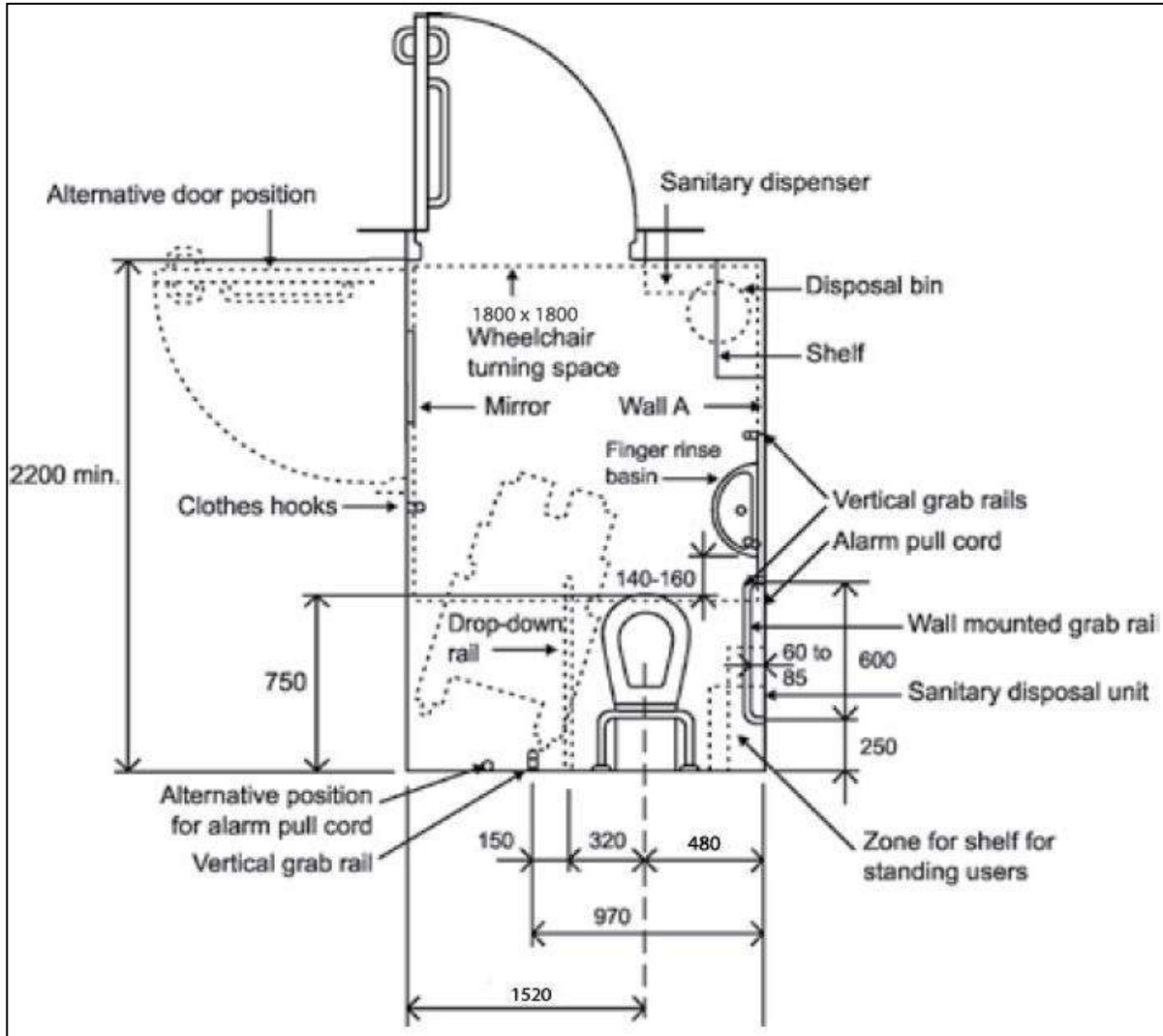

Figure 8-13: Unisex public toilet

9 FIRE EVACUATION NEEDS

Emergency Egress

Provision of accessible means of egress from all public use areas and facilities is as vital a component as accessible ingress.

9.1 Alarm Panels

- Placement (accessibility) and visibility of alerting devices is very important.
- Fire alarm boxes, emergency call buttons and lighted panels should be installed between heights of 800mm and 1000 mm from the finished floor surface.
- These should be adequately contrasted in colour and tone from the background wall and should be labelled with raised letters and also in Braille.

9.2 Alerting Systems

- In emergency situations, it is critical that people are quickly alerted to the situation at hand, for persons with disability the following needs to be considered:
- Audible alarms with 'Voice Instructions' should be installed that can help guide them to the nearest emergency exit. As an alternative to the pre-recorded messages, these alarms may be connected to central control room for on-the-spot broadcasts.
- Non – auditory alarms (visual or sensory) to alert persons with hearing impairments should be installed at visible locations in all areas that the building users may visit (including toilet areas, storerooms etc.). Non-auditory alarms include flashing beacons.

9.3 Evacuation Plans

- Evacuation plans that clearly indicate the designated emergency evacuation routes (Section 9.5.1) as well as location of refuge areas (Section 9.5) should be displayed at all public areas of the building.
- These should contrast strongly against the background. Where possible, these should incorporate raised letters and tactile routes, and Braille for benefit of persons with visual impairments.

9.4 Emergency Evacuation Routes

In buildings or facilities, or portions of buildings or facilities, required to be accessible, accessible means of egress shall be provided in the same number as required for exits by local building/fire safety regulations (National Disability Authority, 1998).

- Designating evacuation routes shall be at least 1500 mm wide, to ensure a wheelchair user and an able bodied person are able to pass each other along the route. The route should be free of any steps or sudden changes in level and should be kept free from obstacles such as bins and flower pots etc.
- An exit stairway to be considered part of an accessible means of egress shall have a minimum clear width of 1500 mm between handrails and shall either

incorporate an area of refuge complying with Section 9.5 within an enlarged floor-level landing or a horizontal exit.

- Orientation and direction signs should be installed frequently along the evacuation route and these should preferably be internally illuminated.
- Whilst the emergency lighting provided by traditional overhead emergency lighting luminaries, conforming to the Indian Standard IS: 9583-1981: Emergency Lighting Units, is acceptable for people who are visually impaired.
- Exit signs shall be in accordance with IS: 4878-1968. Exit signage should also be available in tactile format in the evacuation route.
- Along the emergency route, tactile floor guidance for persons with visual impairments (section 5.1.3) should be provided.

Note: Fireproof doors along circulation paths that are not exclusively egress routes generally require a force greater than 25 N to operate, rendering several disabled people dependent on others to negotiate these doors. While it is essential to cater safety measures for unpredictable emergencies, it is also important to provide an accessible environment to disabled persons. Consider holding the doors open with magnetic catches or 'floor springs' that are connected with the fire alarm system

9.5 Provision of Refuge Areas

- A refuge area, also known as an area of rescue assistance, is a place of relative safety where persons who may not be able to negotiate inaccessible egress routes may await rescue assistance.
- Where a required exit from an occupiable level above or below a level of accessible exit discharge is not accessible, refuge areas shall be provided on each such level (in a number equal to that of inaccessible required exits).
- Every required area of refuge is to be accessible from the space it serves by an accessible egress route.
- Every area of refuge shall have direct access to an exit stairway.
- Each area of refuge must be separated from the remainder of the story by a smoke barrier having minimally one hour fire resistance rating. Each area of refuge is to be designed to minimize the intrusion of smoke.
- The size of the refuge to provide at least two accessible areas each being not less 750 mm by 1200 mm. The area of rescue assistance shall not encroach on any required exit width. The total number of such areas per story shall be not less than one for every 200 persons of calculated occupant load served by the area of rescue assistance.
- All stairs next to the refuge should have a clear width of 1500mm between the handrails.
- A method of two-way communication, with both visible and audible signals, shall be provided between each area of rescue assistance and the primary entry.

9.5.1 Signage

- Each area of rescue assistance shall be identified by a sign, which states "REFUGE AREA" and displays the international symbol of accessibility.
- The sign should be illuminated when exit sign illumination is required.
- Signage should also be installed at all inaccessible exits and where otherwise necessary to clearly indicate the direction to areas of rescue assistance.
- In each area of rescue assistance, instructions on the use of the area under emergency conditions shall be posted adjoining the two-way communication.

10 ALIGHTING AND BOARDING AREAS

10.1 Car Parks

10.1.1 Signage

- International symbol of accessibility (wheelchair sign) should be displayed at approaches and entrances to car parks to indicate the provision of accessible parking lot for Persons with Disabilities within the vicinity.
- Directional signs shall be displayed at points where there is a change of direction to direct Persons with Disabilities to the accessible parking lot.
- Where the location of the accessible parking lot is not obvious or is distant from the approach viewpoints, the directional signs shall be placed along the route leading to the accessible parking lot.
- Accessible parking lot should be identifiable by the International Symbol of Accessibility in accordance to the Section 6.4.7.5. The signs should not be obscured by a vehicle parked in the designated lot.
- Vertical signs shall be provided, to make it easily visible, the sign should be at a minimum height of 2100 mm (Figure 10-1).

10.1.2 Symbol

- International Symbol of Accessibility should be clearly marked on the accessible parking lot for drivers/riders with disabilities only.
- The Symbol painted on the designated lot should comply with Section 6.4.7.5 and the following:
 - A square with dimensions of at least 1000 mm but not exceeding 1500 mm in length;
 - Be located at the centre of the lot; and
 - The colour of the symbol should be white on a blue background.

10.1.3 Car Park Entrance

The car park entrance should have a height clearance of at least 2400 mm.

10.1.4 Location

- Accessible parking lots that serve a building should be located nearest to an accessible entrance and / or lift lobby within 30 meters. In case the access is through lift, the parking shall be located within 30 meters.
- The accessible route of 1200 mm width is required for wheelchair users to pass behind vehicle that may be backing out.

10.1.5 Accessible Car Parking Lot

The accessible car parking lot should:-

- Have minimum dimensions 5000 mm×3600 mm;
- Have a firm, level surface without aeration slabs; and
- Wherever possible, be sheltered.

- Where there are two accessible parking bays adjoining each other, then the 1200mm side transfer bay may be shared by the two parking bays. The transfer zones, both on the side and the rear should have yellow or white cross-hatch road markings.
- Consideration should be given to the distribution of spaces for use by the Persons with Disabilities in accordance with the frequency and persistency of parking needs.
- Two accessible parking lot should be provided for every 25 car parking spaces.

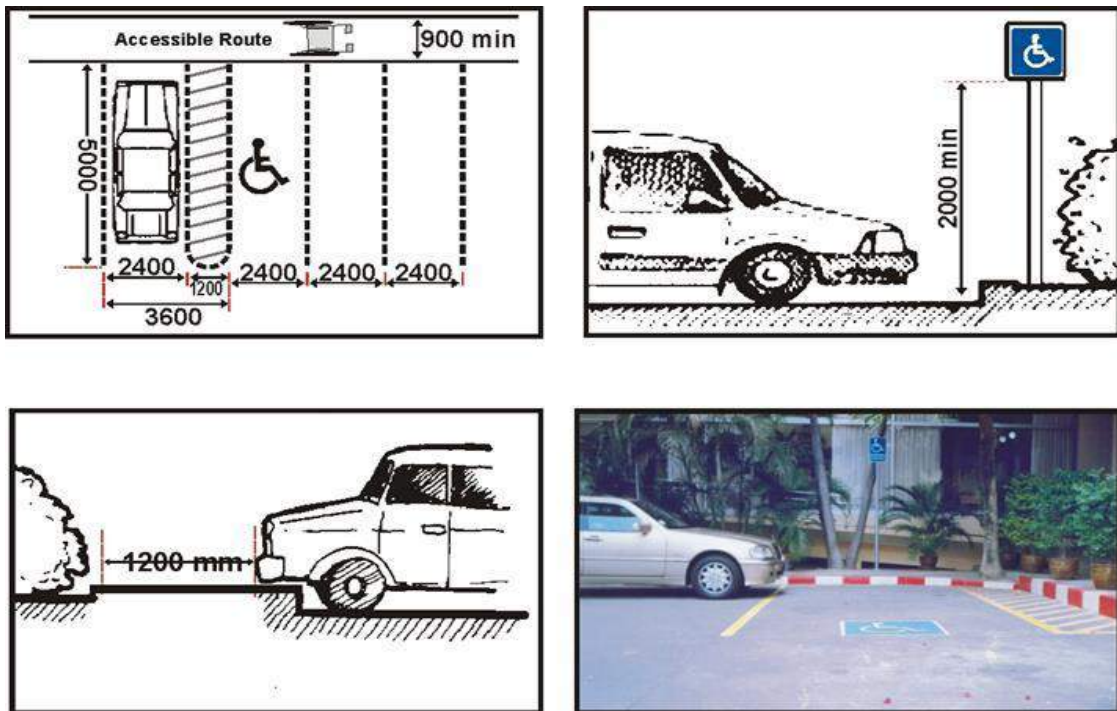

Figure 10-1: Accessible parking standards

10.2 Taxi/Auto Rickshaw Stands

10.2.1 General

- At least one accessible route should be provided from the alighting and boarding point of the taxi stand to the walkway that leads to the accessible building entrance.
- Directional signs should be installed to direct Persons with Disabilities to an accessible entrance.
- Guiding blocks should be provided along the accessible walkway from the taxi stand to the building entrance for the aid of persons with vision impairments.
- The sign indicating the presence of a Taxi/Auto Rickshaw Stand shall be on a vertical pole and the sign should be visible after dark (35 – 40 Lux).
- A taxi bay should, where possible be provided at the level of approach or Persons with Disabilities to alight and to board the vehicle.

- Where transfer has to be made from a vehicular surface to a pedestrian surface, the driveway, pathway or walkway should be blended to a common level or be ramped.

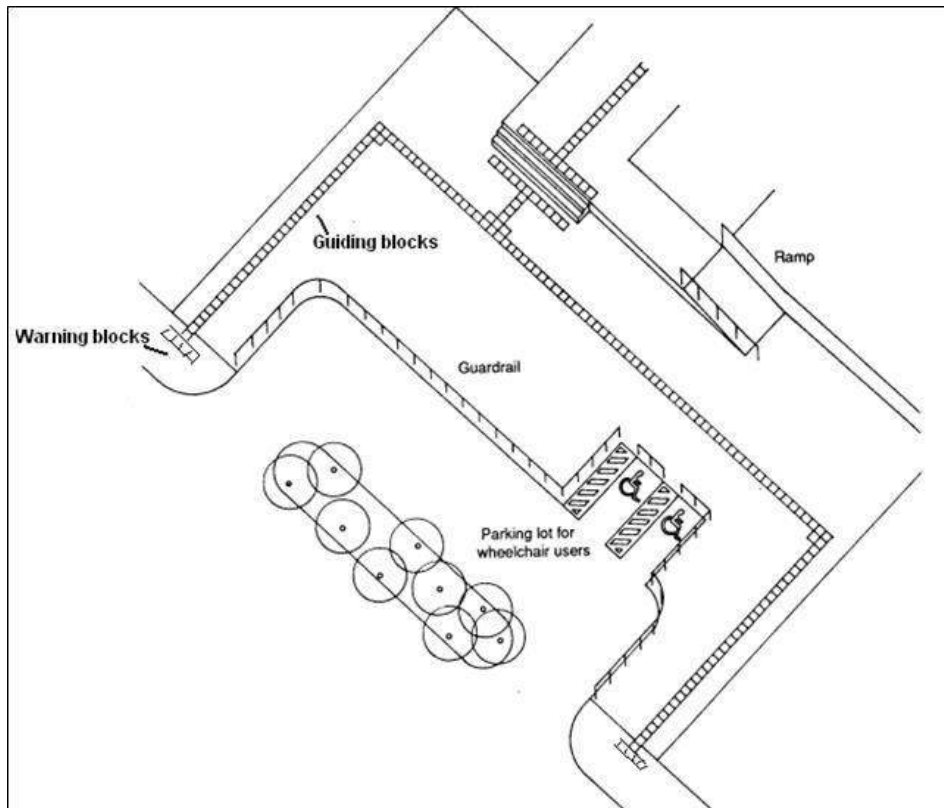

Figure 10-2: General plan of parking

10.2.2 Passage Way

- Continuity of the pedestrian pathway shall be maintained to a minimum width of 1200mm behind the taxi stand.

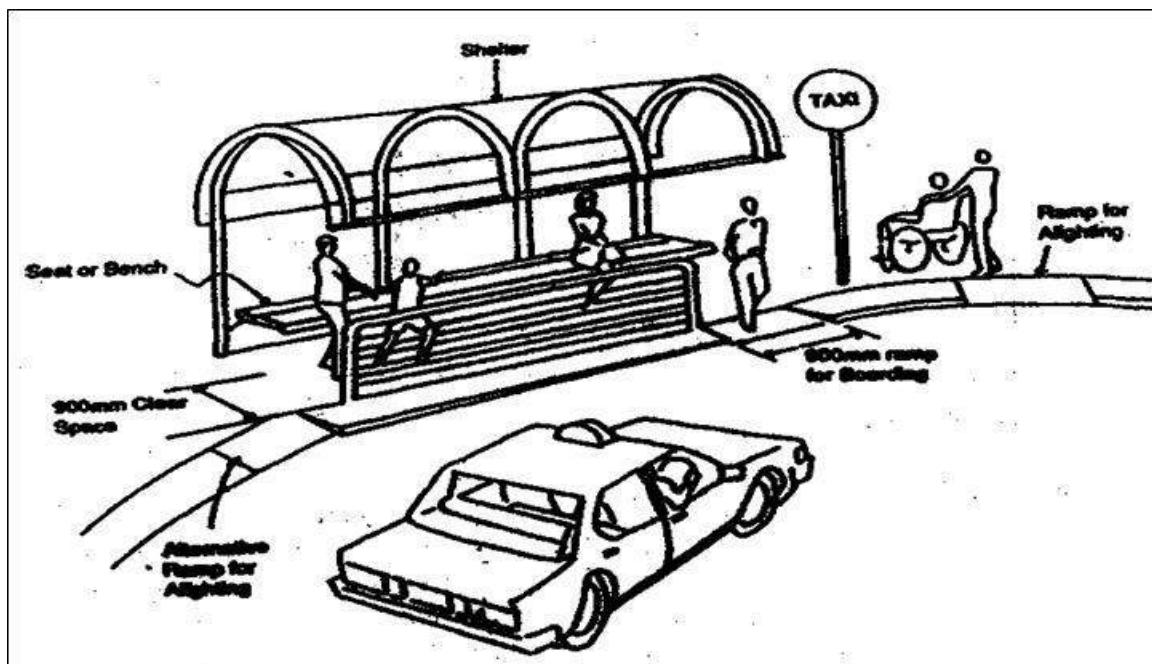

Figure 10-3: Layout for accessible taxi/car boarding

10.2.3 Handrails

Handrails should:-

- Comply with Section 5.9; and
- Be installed at two levels 760mm and 900 mm from the floor level.

10.2.4 Ramps

- Where a taxi stand is not on the same level with the walkway or pathway, it should have two separate ramps for boarding and alighting as shown in the Figure 10-3.
- Where there are kerbs between the access aisle and the vehicle pick-up space, it should have a kerb ramp.

10.2.5 Seats

- Seats should be provided at the taxi stand for people with ambulatory disabilities.
- These seats should be positioned such as not to impede the movement of wheelchair users and persons with vision impairment.

10.2.6 Shelter

- A shelter should be provided at the taxi stand for protection against adverse weather conditions.

10.3 Bus Stops

10.3.1 General

- At least one accessible route should be provided from the alighting and boarding point of the bus stand to the walkway that leads to the accessible building entrance.
- Directional signs should be installed to direct Persons with Disabilities to an accessible entrance.
- Guiding blocks should be provided along the accessible walkway from the bus stand to the building entrance to aid persons with visual impairments.
- The bus stand shall have minimum illumination level of 35 to 40 lux.

10.3.2 Location

- Bus stand should be located nearest to an accessible entrance.
- Where transfer has to be made from a vehicular surface to a pedestrian surface, the driveway, pathway or walkway should be blended to a common level or be ramped.

10.3.3 Passage Width

- A clear passageway with a minimum width of 1200mm should be provided.



Figure 10-4: Bus stop design

10.3.4 Seats

Seats should be provided at the bus stand for people with ambulatory disabilities. These seats should be positioned such as not to impede the movement of wheelchair users.

10.3.5 Shelter

A shelter should be provided at the bus stand for protection against adverse weather conditions.

10.3.6 Ramps

- Where a bus stand is not on the same level with the walkway or pathway, it should have two separate ramps for boarding and alighting, conforming to Table 7.1.
- Where there are curbs between the access aisle and the vehicle pick-up space, it should have a kerb ramp complying with Section 7.1.

10.4 Railway Stations and Airports

10.4.1 Level Approach

- Approach route should not have level differences. If the station is not on the same level as the walkway or pathway, it should have a ramp conforming to Table 7.1.
- Walkway surfaces should be non-slip.
- Approach walkway should have tactile pavements for persons with visual impairments.

10.4.2 Station Entrances and Exits

- These should have a minimum width of 1800mm and is level or ramped, complying with Table 7.1.

10.4.3 General Station Interiors

- There should be a tactile layout map of the station with Braille and audio labels placed at the entrance. Tactile map should be marked by floor tactile guidance for persons with visual impairments to access it.
- The lobby/corridor width should be at least 1800 mm.
- The floor surfaces should be non-slip and level.
- There should be directional signs indicating all the facilities and the various platform numbers.
- The signage should also be displayed in Braille/raised numbers to aid people with visual impairments.
- Guiding and warning blocks should be installed on the corridors/concourse.
- Stairs should comply with Section 7.3.
- Lifts should comply with Section 7.4.
- All the audio announcements should be supplemented with visual information displays for people with hearing impairments.
- Seating areas should be provided at regular intervals for people with ambulatory disabilities.

10.4.4 Reservation and Information Counters

- Should have clear floor space of at least 900 mm x 1200 mm in front of the counters;
- There should be at least one low counter at a height of 750 mm to 800 mm from the floor with clear knee space of 750 mm high by 900 mm wide by 480 mm deep (Figure 10-5);
- At least one of the counters should have an induction loop unit to aid people with hearing impairments; and
- The counters should have pictographic maps indicating all the services offered at the counter and at least one of the counter staff should be sign language literate



Figure 10-5: Counter tops

10.4.5 Toilet Facilities

There should be at least one unisex accessible toilet complying with Chapter 8.

10.4.6 Ticket Gates

At least one of the ticket gates should:-

- Be minimum 900 mm wide to allow a wheelchair user through; and
- Have a continuous line of guiding blocks for people with visual impairments.

10.4.7 Platforms

Platforms should:

- Have a row of warning blocks installed 600mm before the track edge (Figure 10-6);
- Have non-slip and level flooring;
- Have seating areas for people with ambulatory disabilities;
- Be well illuminated, lux level 35 to 40;
- There should be no gap or difference in level between the train entry door and the platform (Figure 10-7 and 10-8);
- All platforms should inter-connect by means of accessible routes or lifts (Section 7.4);and
- Provide accessible level entrance to the train coach.

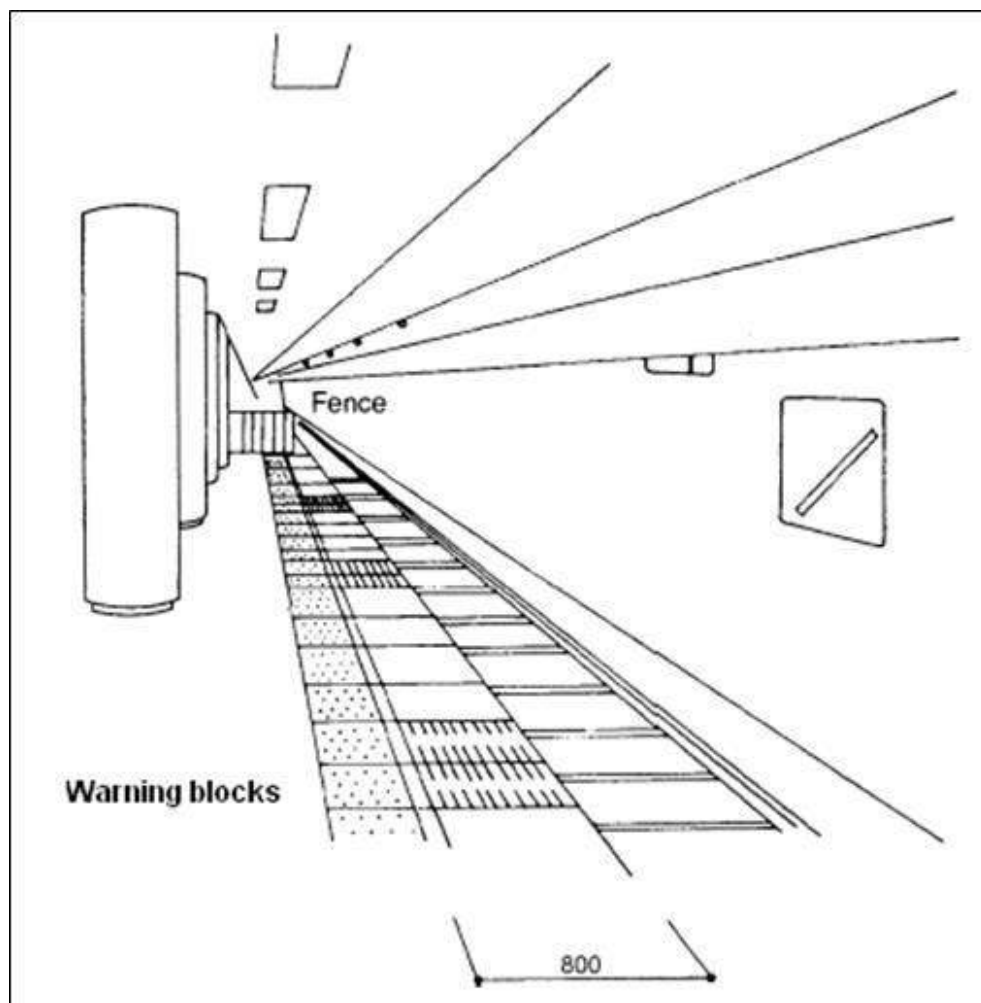

Figure 10-6: Warning blocks on platform edges



Figure 10-7: Level boarding in Delhi metro Rail Coach



Figure 10-8: Warning strip on platform

Airports have similar requirements as detailed in section above.

10.5 Piers and Jetties

10.5.1 General

- All forms of water transport should be accessible to people with disabilities;
- Ferries should be fitted with accessible ramps complying with Table 7.1;
- Within a cabin, space should be set aside for securing a wheelchair in a position for comfortable integration with other passengers;
- Piers should be fully accessible and have simple boarding and disembarkation procedures; and
- Guidelines for designing accessible piers and jetties are similar to the ones for railway stations except for the platform.

11 TRANSPORT AND ROAD PLANNING

11.1 Sidewalks / Footpaths

- Sidewalk should:
 - Have non-slip floor surface;
 - Be along the entire length of the road;
 - Be not more than 150mm high;
 - Be at least 1800 mm wide;
 - Have tactile guiding blocks for persons with visual impairments;
 - Preferably have well defined edges of paths and routes by use of different colours and textures;
 - Have no obstacles or projections along the pathway. If this is unavoidable, there should be clear headroom of at least 2000 mm from the floor level;
 - Have kerb cuts complying with Section 7.1 where ever a person is expected to walk into or off the pathway; and
 - Have tactile warning blocks installed next to all entry and exit points from the pathway.

11.2 Kerb Ramps at Walkways and Pedestrian Crossings

Kerb ramp at pedestrian crossing should be wholly contained in the area designated for pedestrians use (Figure 11-1). At the pedestrian crossings, i.e. for the kerb ramps, tactile floor guidance should be provided. Zebra crossings should be in 3D texture to be easily detectable by persons with visual impairments

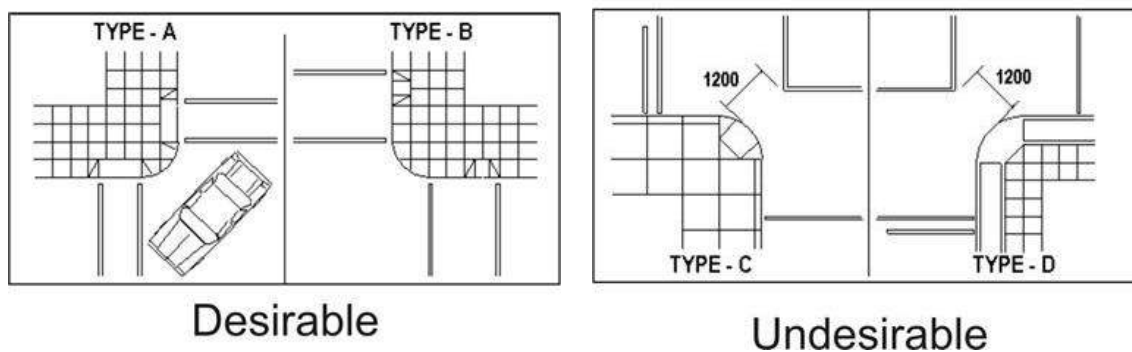

Figure 11-1: Kerb ramp placements at turnings

11.3 Road Intersections

- Pedestrian crossings should be equipped with traffic control signal;
- Constructing traffic islands to reduce the length of the crossing is recommended for the safety of all road users;
- Guide strips should be constructed to indicate the position of pedestrian crossings for the benefit of people with visual impairments; and
- Road bumps are helpful in reducing the speed of traffic approaching the intersection.

11.4 Median Refuge/Islands

- Raised islands in crossings should:-
 - Be cut through and level with the street (Figure 11-2); or
 - Have kerb ramps, complying with Section 7.1 at both the sides and have a level area of not less than 1500 mm long in the middle; and
 - A coloured tactile marking strip at least 600 mm wide should mark the beginning and the end of a traffic island, to guide pedestrian with visual impairments to its location

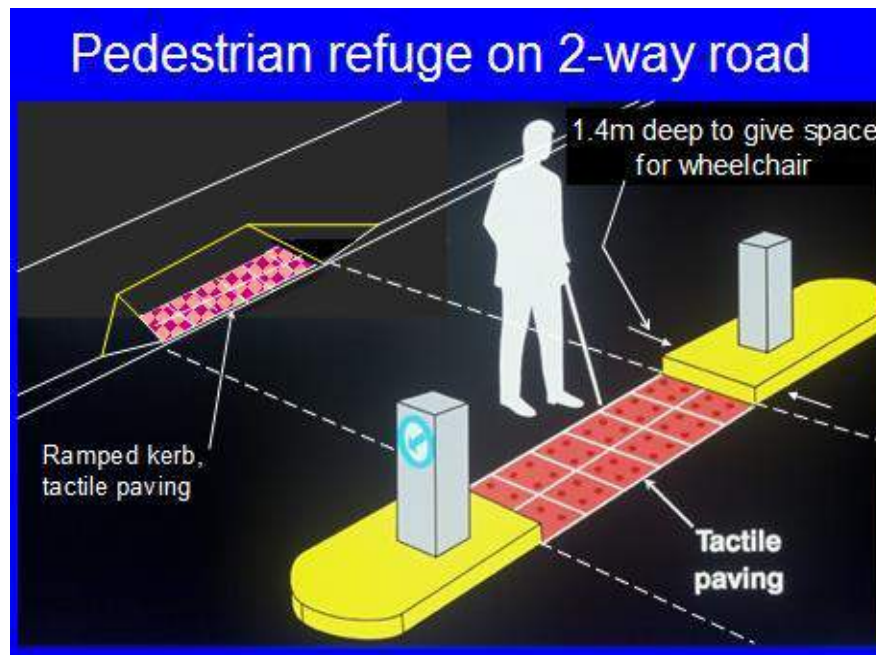

Figure 11-2: Median refuge/island

11.5 Traffic signals

- Pedestrian traffic lights should be provided with clearly audible signals for the benefit of pedestrians with visual impairments;
- Acoustic devices should be installed on a pole at the point of origin of crossing and not at the point of destination;
- The installation of two adjacent acoustic devices such as beepers is not recommended in order to avoid disorientation;
- The time interval allowed for crossing should be programmed according to the slowest crossing persons; and
- Acoustical signals encourage safer crossing behaviour among children as well.

11.6 Subways and Foot Over Bridges

Subways and foot over bridges should be accessible for people with disabilities. This may be achieved by:

- Provision of signage at strategic location;
- Provision of slope ramps or lifts at both the ends to enable wheelchair accessibility (Figure 11-3 and 11-4) ;

- Ensuring that the walkway is at least 1500 mm wide;
- Provision of tactile guiding and warning blocks along the length of the walkway;
- Keeping the walkway; free from any obstructions and projections; and
- Providing for seats for people with ambulatory disabilities at regular intervals along the walkway and at landings.

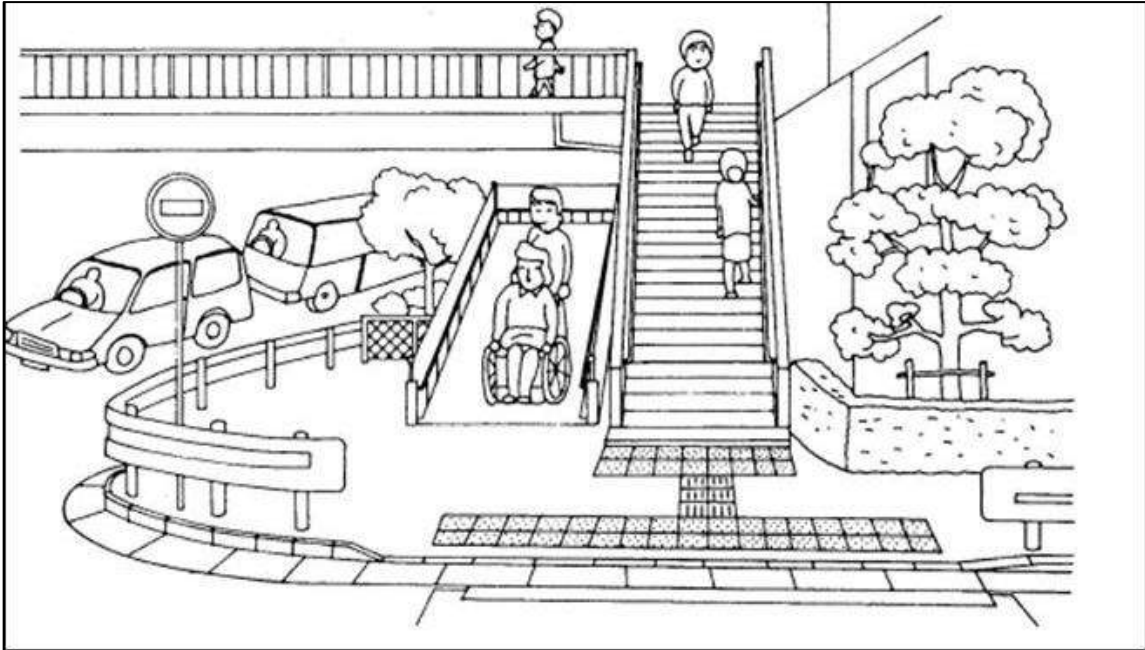

Figure 11-3: Pedestrian foot over ridge with ramp and steps



Figure 11-4: Pedestrian foot over bridge with ramp and lift facilities



Figure 11-6: Lift access to Foot Over Bridge



Figure 11-5: Lift access to subway crossing

11.7 Public Transport

11.7.1 Land Transport

11.7.1.1 General

- Buses, trams, taxis, mini-buses and three-wheelers should be designed as far as practicable to include facilities that can accommodate people with disabilities.
- New vehicles when purchased should comply with accessibility standards to enable all people, including those in wheelchairs, to use the service provided.
- Equally important, travel routes to bus stops should also be barrier-free to ensure that persons can travel from their homes to their chosen pick-up point. Training should be provided for drivers to help them become aware of the needs of Persons with Disabilities.
- For details regarding accessible bus stops refer to Section 10.3.

11.7.1.2 Accessible buses

Accessible buses should have the following features:

- Bus doors should be at least 1200 mm wide;
- Should be low floor;
- Have handrail and footlight installed; and
- Have apparatus such as a hydraulic lift or pull-out/foldable ramp (Figure 11-7) installed in the doorway for mobility aided users/ prams.
- Wheelchair spaces
 - Space for a wheelchair should be provided in an appropriate position, without preventing other passengers from getting on and off (Figure 11-8);
 - The location of that space should be as indicated, inside and outside the bus, using the standard symbol for wheelchair accessibility; and
 - Wheel stoppers and wheelchair safety belts should be provided



Figure 11-7: Low floor bus boarding from road level and bus stand platform

- Alighting Buzzer
 - An appropriate number of alighting buzzers should be provided in positions that are easily accessible for seated or standing passengers; and
 - The push button of an alighting buzzer should be clearly visible; of adequate size, installed at 900 mm to 1200 mm from the bus floor level and display the information in Braille/raised numbers as well.

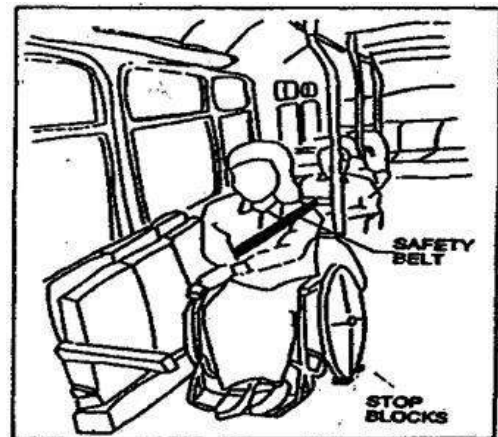

Figure 11-8: Wheelchair space in bus

- Information Signs
 - Information on the names of all stops along a bus route should be indicated inside the bus by displaying the text in a suitable position; and
 - Information on a route and its final destination should be displayed outside the bus in large text, especially on the front and side of the bus. This information should be in a bright contrasting colour and be well illuminated by an external light to make it readable in the dark.

11.7.1.3 Taxi

- Taxi should be adapted to allow passengers to get in and out of them while remaining seated in their wheelchairs (Figure 11-9).

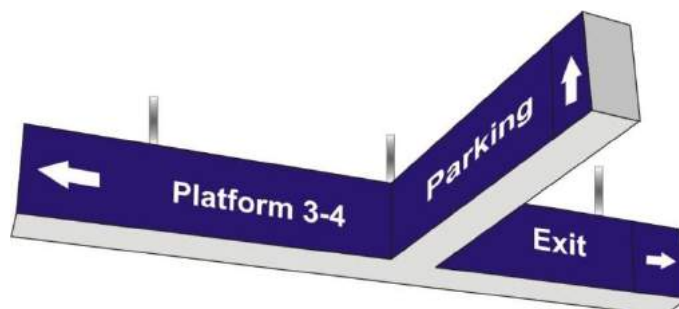

Figure 11-9: Accessible taxi

11.7.2 Rail Transport

11.7.2.1 General

- Whether over-ground or underground, rail travel is a highly effective mode of transport.
- Every train should contain fully accessible carriages.
- For persons with hearing impairments, an electronic signboard (digital display) should be displayed on each platform at conspicuous location for all announcements made by the railways.
- Staff should be trained in methods of assistance and be at hand on request.
- Stations for all rail travel should be fully accessible with extra wide turnstiles where possible alongside wheelchair accessible doorways complying with Section 5.7.
- Staff should be on hand to assist Persons with Disabilities to enter or exit through convenient gates.
- All new railway stations should be designed to be fully accessible, while those being retrofitted should comply with standards given in these Guidelines.
- For



details regarding accessible railway stations refer to Section 10.4.

Figure 11-10: Information boards on platforms/concourse

11.7.2.2 Accessible Railway Cars

Railway cars should have the following features:

- Railway car doors should be at least 900 mm wide;
- The gap between the car doors and the platform should be less than 12 mm;
- Identification signage on the door for wheelchair accessible coach (Figure 11-11); and
- If the car door and the platform cannot be at the same level, then at least one car door should have apparatus such as a hydraulic lift or pull-out ramp (Figure 11-12) installed in the doorway for wheelchair users.

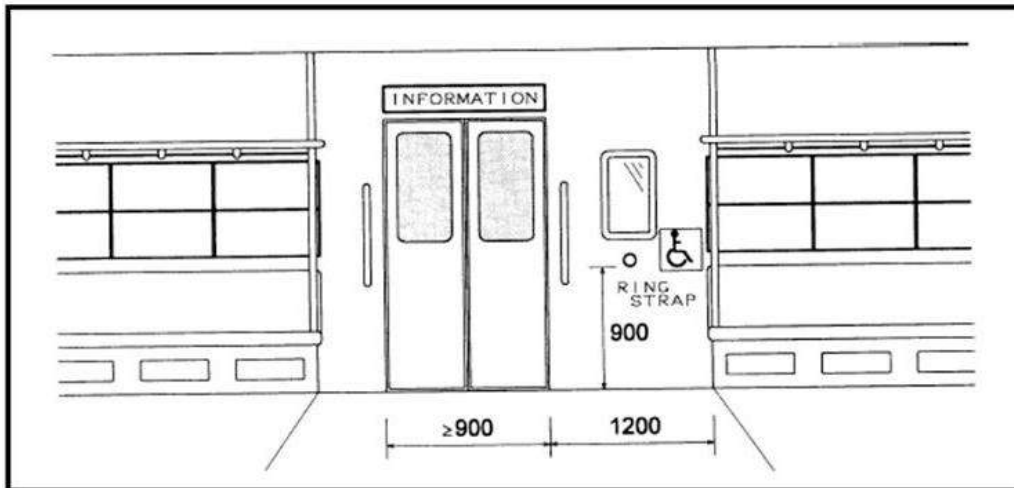

Figure 11-11: Rail/ Metro door signage



Figure 11-12: Retrofitting of ramp for sub-urban rail

- Wheelchair space
 - Space for a wheelchair should be available at the side of the door(Figure 11-13);
 - The space should be indicated inside and outside the car by using the international symbol of accessibility ; and
 - Wheel stoppers and ring-strap or other appropriate safety grip should be provided for wheelchair users.

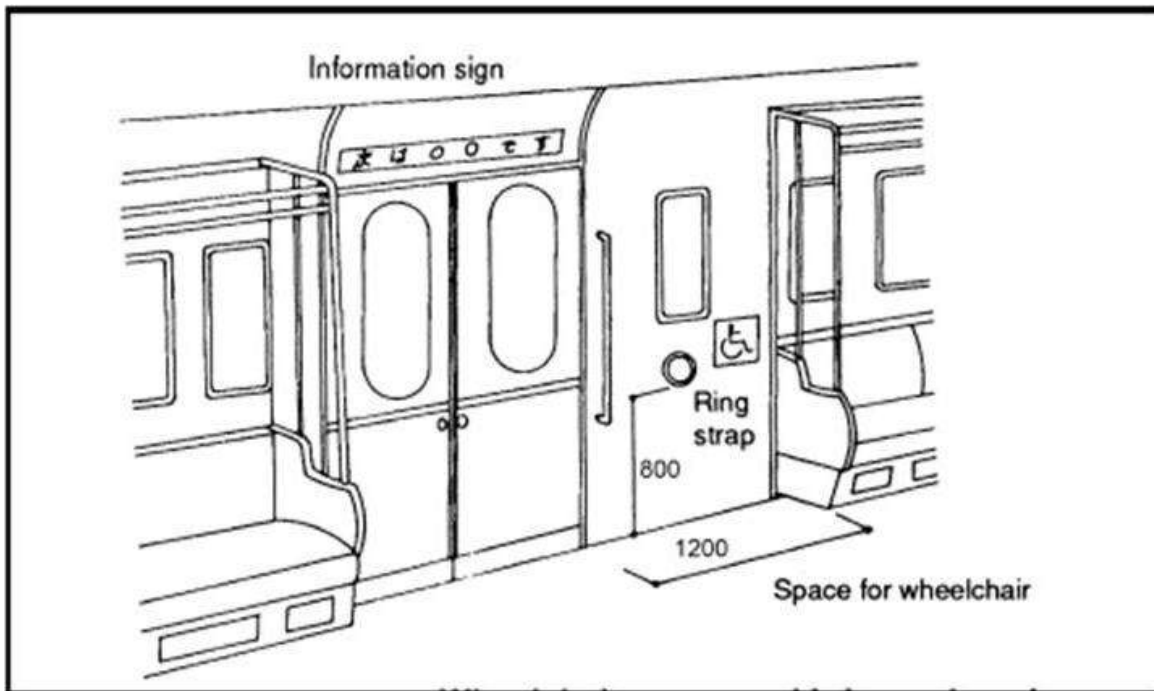

Figure 11-13: Reserved space for wheelchair user

- Seats
 - An appropriate number of designated seats for passengers with disabilities and elderly people should be provided near the doors.
- Aisles
 - Aisles should be at least 900 mm wide.
- Information Signs and Announcements
 - A map of train routes should be installed. This should be in Braille/raised numbers as well;
 - In each car, there should be an announcement and provision of a visual display of the names of stations route. This display should be in raised numbers with sharp contrast from the background.

11.7.3 Water and Air Transport Crafts



Figure 11-14: Accessible ferry

11.7.3.1 Water transport crafts: Ship and Ferry Interior

- Doors should be at least 900 mm wide.
- Aisles should be at least 800 mm wide.
- An accessible toilet and shower cubicle should be provided on board the ship, complying with Section 8.2 and 8.12.
- Wheel stoppers and ring-strap or other appropriate safety grip should be provided for wheelchair users.

11.7.3.2 Air Transport Crafts

- All aircraft should have the capacity to safely accommodate wheelchair passengers.
- All airports should be fully accessible and have appropriate boarding facilities.
- Special attention should be given to accessible toilet facilities on board aircraft. For details regarding accessible airports refer to Section 10.4.

11.7.3.3 Aircraft Interior

- Doors should be at least 900 mm wide;
- Aisles should be at least 750 mm wide;
- An accessible toilet cubicle should be provided on board the aircraft, complying with Section 8.2 & 8.12; and
- Plugs should be accessible for passengers requiring their respirators to be plugged into electricity outlets.

12 ADAPTED HOUSING

12.1 Exterior

12.1.1.1 *Route of Entry should:*

- Have hard, non-slip and even surface;
- Be free of loose gravel;
- Provide continuing common surface not interrupted by steps or sudden changes in level and other obstructions such as manhole covers, light or telephone poles;
- Be marked with signage in Braille and visual signage at appropriate height to indicate the shopping area, apartment blocks, bus stop, taxi stand, etc.;
- If there is more than one entry to the dwelling, the most accessible one should be selected considering proximity to the driveway, most level walking surface, height of stairs and available handrails; and
- The driveway should provide easy access to the home by means of a walkway that is level and free of cracks and uneven surfaces. For details regarding accessible parking refer to Section 10.1.
- Stairs should conform to Section 7.3 and be provided with handrails conforming to Section 5.9.3.
- If a ramp is to be installed, it should conform to Section 7.2.

12.1.2 Entrance

- Entrance should be well lit and be provided with an adequate cover from adverse weather conditions.
- For wheelchair users, the entrance should have a platform of at least 1500 mm x 1500 mm. This will enable the person to rest and prepare for entry.

12.2 Interior

12.2.1 Furniture Arrangement

- Sufficient room should be made available for manoeuvring a wheelchair (at least 1500 mm turning radius) or ambulating with an assistive device such as a walking frame or a white cane;
- Clear passage should be allowed from one room to the next;
- Unrestricted access should be provided to electrical outlets, telephones and wall switches;
- All controls and operating mechanisms should comply with Section 5.10; and
- A clear floor space for the wheelchair, of at least 900 mm x 1200 mm should be provided in front of all the utilities and furniture.

12.2.2 Floor surface

- Floor surface should comply with Section 5.5.4.

12.2.3 Doors

- Should comply with Section 5.7;
- Should have handles complying with Section 5.7.9;

Knurled surface door handles should be used on interiors of dwellings frequented by people with visual impairments. These abrasive, knurled surfaces indicate that the door opens to a hazardous area and alerts the individual to danger.

- Glass doors should be marked with a bright coloured motif at eye level to aid people with low vision.

12.2.4 Stairs

- Should comply with Section 7.3.
- Should be well lit.

12.3 Bedroom

- The bedroom should be planned to provide a 1500 mm turning in space for wheelchair, at least near all the doors.
- There should be a clear floor space of at least 900 mm × 1200 mm in front of all furniture.
- Bed for a wheelchair user should:
 - Have a height of 450-480 mm from the floor surface;
 - Be stable. Stability may be improved by placing the bed against a wall or in corner of the room (except for when the wheelchair user plans to make the bed); and
 - Be positioned to provide at least a 1500 mm turning in space at the transfer side
- A bedside table or cabinet between 450 mm and 900 mm from the floor may be useful to hold a lamp telephone, necessary medications and a call bell if assistance is needed.
- Wall hook installed at a height of 1100 mm to 1300 mm may be a useful addition to the closet area.
- The closet should:
 - Have a clear floor space of at least 900 mm × 1200 mm;
 - Have the clothes bar at a height of 1200 mm from the floor;
 - Have shelves installed at various levels between 300 mm and 1150 mm from the floor surface;
 - Have door handle conforming to Section 5.7.9

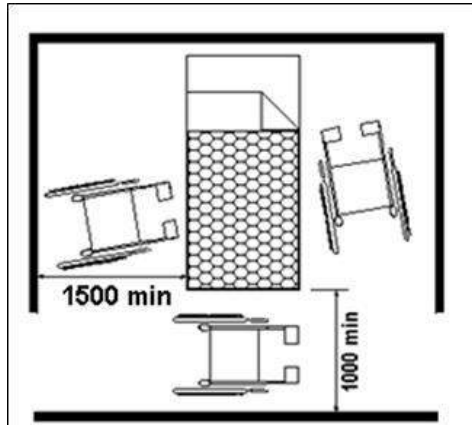

Figure 12-2: Space around bed

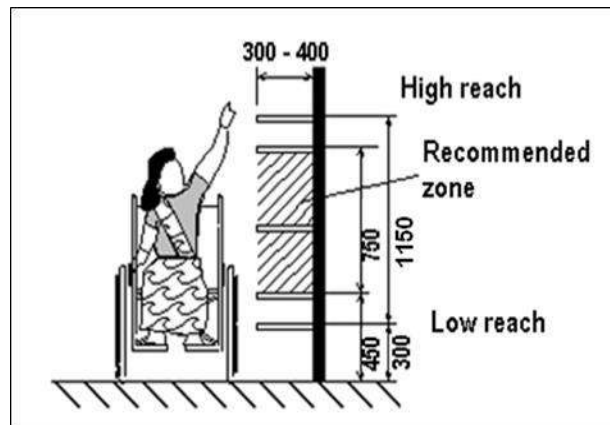

Figure 12-1: Storage space

12.4 Living Room

- At least 1500 mm turning in space for wheelchair should be provided near all entry points to the living room.
- A living-dining combination is preferable to a kitchen-dining combination (except when the wheelchair user does the cooking).
- The seating space for a wheelchair user at the dining table should provide a clear knee space. The clear knee space for a wheelchair user is at least 900 mm wide, 480 mm deep and 750 mm high.
- Floor surface should comply with Section 5.5.4.
- There should be a clear floor space for the wheelchair of at least 900 mm x 1200 mm in front of all the fixtures.
- Chair seat heights should not be less than 500mm.
- Controls and operating mechanisms should comply with Section 5.10.

12.5 Washroom

- Should comply with Section 8.2.

12.6 Kitchen

- Wheelchair turning radius of at least 1500 mm should be provided between the counter and the opposite walls.
- Floor surface should allow for easy wheelchair manoeuvrability.
- Counter tops
 - Counter tops should be between 750 mm and 800 mm in height and provide for clear knee space for a wheelchair user. The clear knee space for a wheelchair user is at least 900 mm wide, 480 mm deep and 750 mm high (Figure 12-4);
 - Counter tops/slabs should have rounded edge;
 - All surfaces should be smooth to facilitate sliding of heavy items from one area to another;
 - Slide-out working spaces are useful in providing an over-the lap working surface;

- For people with ambulatory disabilities, stools (preferably with back and foot rests) should be provided strategically at the main work area;
- Shelves and storage spaces should be between 300 mm and 1200 mm height from the floor surface;
- All controls and operating mechanisms should comply with Section 5.10; and
- Any exposed hot-water pipes under the sink should be insulated to avoid burns.

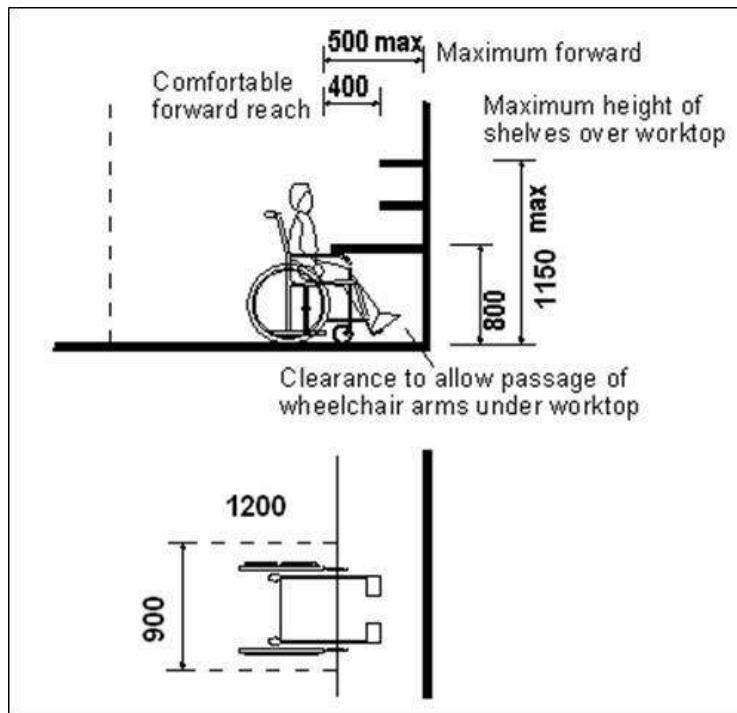

Figure 12-3: Shelves and cupboards

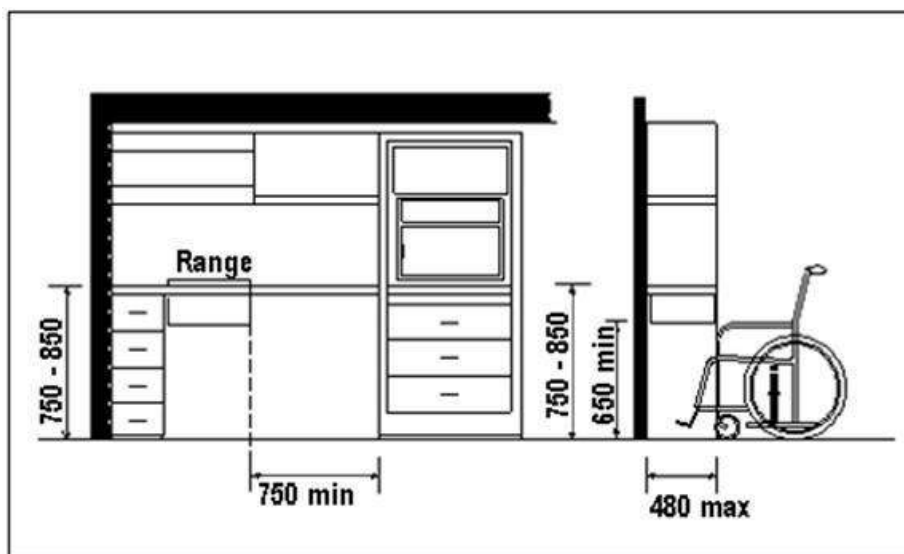

Figure 12-4: Kitchen shelves and cabinets

13 ACCESS AUDIT CHECKLIST

Many buildings and areas would require redesigning and retrofitting to ensure a barrier free environment for persons with disability and the elderly. A comprehensive audit checklist has been formulated to review the accessibility of spaces for ready reference.

Building Name _____

Date of Audit _____

Audit done by _____

1. MAIN ENTRANCE	YES	NO	NOT APPLICABLE	REMARKS
▪ Is the main entrance of the building accessible?				
▪ Are there any steps at the entrance?				
▪ Do the steps have a handrail?				
▪ Are there handrails on both the sides?				
▪ Is there a ramp?				
▪ Does the ramp have a railing?				
▪ Are there handrails on both the sides?				
▪ Is the clear door width at least 1000 mm?				
▪ Can the entrance door be operated independently?				
▪ Is the height of the door handle between 800 mm and 1000 mm?				
▪ Does the accessible entrance permit access to an elevator?				
▪ Is the accessible entrance clearly identifiable?				
▪ Is the landing surface non-slippery?				

2. RAMPS	YES	NO	NOT APPLICABLE	REMARKS
▪ Is there a ramp next to the stairs?				
▪ Is the location of the ramp clearly identifiable?				
▪ Is the ramp gradient no steeper than 1:12?				
▪ Is there a landing of at least 1500 mm x 1500mm, at 9m intervals provided?				
▪ Is there a landing at every change in direction?				
▪ Is there landing at the top and bottom of every ramp?				
▪ Is the minimum width of the ramp 1500 mm?				
▪ Are there continuous handrails, on both sides, at a height between 760 mm – 900 mm?				
▪ Is the surface of the ramp non-slip?				
▪ Is there an edge protection on both sides of the ramp?				

3. PARKING	YES	NO	NOT APPLICABLE	REMARKS
▪ Are there accessible parking facilities?				
▪ Is the number of accessible parking spaces sufficient?				
▪ Are the designated spaces wide enough 3600mm x 5m?				
▪ Are accessible parking spaces marked by the international symbol of accessibility?				
▪ Accessible parking spaces are not misused or used by non-disabled people?				
▪ If the drop-off area has a kerb, is there a kerb ramp leading to the pathway?				
▪ Is the drop-off area marked by signage?				
▪ Is there an accessible path of travel from the drop-off area to the main entrance?				

4. RECEPTION & INFORMATION COUNTERS	YES	NO	NOT APPLICABLE	REMARKS
▪ Are the counters easily indefinable?				
▪ Is the counter at two height?				
▪ Is a part of the counter lowered to accessible height of 800 mm?				
▪ Is a loop induction unit installed at the counter?				
▪ Are there tactile pictographic maps of the building near the counter?				
▪ Is the counter well illuminated?				

5. DOORS	YES	NO	NOT APPLICABLE	REMARKS
▪ Are there any automatic doors at the entrance?				
▪ Can the doors be operated without much effort?				
▪ Do automatic doors have sufficient long opening intervals?				
▪ Are push buttons for automatic doors located at a maximum height of 1m?				
▪ Is there sufficient space beside the latch side of the doors (450-600mm)?				
▪ Are accessible door placed adjacent to the revolving doors and turnstiles?				
▪ Are glazed doors marked with a colour band at eye level?				
▪ For double leaf doors, is the width of one of the leaves at least 1m?				
▪ Do doors fitted with spring closers have an extra pull handle?				
▪ Is manual door accessories/hardware (handle, lock pull etc.) lower than				

800mm?				
6. CORRIDORS	YES	NO	NOT APPLICABLE	REMARKS
<ul style="list-style-type: none"> ▪ Is the minimum unobstructed width of corridors at least 1500 mm? 				
<ul style="list-style-type: none"> ▪ Does the corridors width allow manoeuvring through doors located along its length? 				
<ul style="list-style-type: none"> ▪ Are differences in level, bridged with by ramps or lifts? 				
<ul style="list-style-type: none"> ▪ Can a sightless person with a cane detect all protruding objects with in the corridor? 				
<ul style="list-style-type: none"> ▪ Are all over hanging obstructions mounted above a minimum height of 2200mm? 				
<ul style="list-style-type: none"> ▪ Can a person with low vision, identify all obstacles in the corridor? 				

7. LIFTS	YES	NO	NOT APPLICABLE	REMARKS
<ul style="list-style-type: none"> ▪ Is there an accessible path leading to the elevator? 				
<ul style="list-style-type: none"> ▪ Is the clear door opening width 1m or more? 				
<ul style="list-style-type: none"> ▪ Are the minimum internal dimensions of the elevator 1500 mm x1500 mm minimum or having 13 persons capacity? 				
<ul style="list-style-type: none"> ▪ Is the height of the call button (outside the lift) between 800 mm – 1m, from the floor level? 				
<ul style="list-style-type: none"> ▪ Is the control panel placed at a height between 800 mm – 1m, from the floor level? 				
<ul style="list-style-type: none"> ▪ Is there an audio and video system installed in the lift indicating arrival at a floor? 				
<ul style="list-style-type: none"> ▪ Are there Braille/raised numbers on the control panel? 				
<ul style="list-style-type: none"> ▪ Is the elevator provided with a handrail on the three sides? 				
<ul style="list-style-type: none"> ▪ Are the handrails mounted at a height between 800 mm and 1m? 				
<ul style="list-style-type: none"> ▪ Is the elevator door easy to identify? 				
<ul style="list-style-type: none"> ▪ Is the emergency intercom provided inside the elevator? 				
<ul style="list-style-type: none"> ▪ Are there tactile or Braille instructions for the communication system? 				
<ul style="list-style-type: none"> ▪ Is the emergency intercom usable without the voice communication? 				
<ul style="list-style-type: none"> ▪ Is the door opening/closing interval long enough? 				
<ul style="list-style-type: none"> ▪ Is the finish of the elevator floor skid-resistant? 				

8. STAIRS	YES	NO	NOT APPLICABLE	REMARKS
<ul style="list-style-type: none"> ▪ Is the minimum width of the stairs 1200mm? 				
<ul style="list-style-type: none"> ▪ Are there continuous handrails, on both sides, at a height between 760mm-900mm? 				
<ul style="list-style-type: none"> ▪ Is the handrails installed in the centre of the stair width, which is more than 3m wide? 				
<ul style="list-style-type: none"> ▪ Is the landing length not less than 1200mm? 				
<ul style="list-style-type: none"> ▪ Are the step edges of a different colour or texture easily identifiable by low-vision & vision impaired persons? 				
<ul style="list-style-type: none"> ▪ Are there warning blocks installed at the beginning and end of all flights? 				
<ul style="list-style-type: none"> ▪ Is the location of emergency (fire escape) stairs clearly identifiable? 				
<ul style="list-style-type: none"> ▪ Does the height of the risers is 150 mm maximum & tread 300 mm minimum? 				
<ul style="list-style-type: none"> ▪ Do treads have a non-slip surface? 				
<ul style="list-style-type: none"> ▪ Are the risers having open gaps in the steps? 				

9. HANDRAILS	YES	NO	NOT APPLICABLE	REMARKS
<ul style="list-style-type: none"> ▪ Are handrails mounted at a height between 760mm – 900 mm? 				
<ul style="list-style-type: none"> ▪ Are handrails easy to grip? 				
<ul style="list-style-type: none"> ▪ Are handrails securely attached? 				
<ul style="list-style-type: none"> ▪ Do handrails extend horizontally 300 mm at the top and bottom of every staircase or ramp? 				
<ul style="list-style-type: none"> ▪ Are the ending of the handrails grouted in the ground or turn downward? 				
<ul style="list-style-type: none"> ▪ Is the space between the handrails and the wall no less than 50mm? 				
<ul style="list-style-type: none"> ▪ Are the handrails painted in contrast colours to be easily identifiable? 				
<ul style="list-style-type: none"> ▪ Are there tactile strip/ Braille plates identifications on the handrails for emergency stairs & floor levels? 				

10. TOILETS	YES	NO	NOT APPLICABLE	REMARKS
<ul style="list-style-type: none"> ▪ Are there accessible toilets for Persons with Disabilities? 				
<ul style="list-style-type: none"> ▪ Are the toilets easily identifiable? 				
<ul style="list-style-type: none"> ▪ Is there sufficient space of 2m x 2.2m inside the toilets to manoeuvre a wheelchair? 				
<ul style="list-style-type: none"> ▪ Are water closet (WC) and bidets mounted at a height between 450mm – 480mm? 				
<ul style="list-style-type: none"> ▪ Is the space between the WC and the closest adjacent wall, fitted with a grab bar is between 450 mm – 500mm? 				
<ul style="list-style-type: none"> ▪ Is the accessible washbasin mounted at a height between 750mm – 850mm? 				
<ul style="list-style-type: none"> ▪ Is the lower edge of the mirror positioned at a height not exceeding 1m? 				
<ul style="list-style-type: none"> ▪ Are the accessible showers provided with a folding seat? 				
<ul style="list-style-type: none"> ▪ Are the grab bars installed near WC and showers at a height between 750 – 850 mm? 				
<ul style="list-style-type: none"> ▪ Do grab bars have a diameter of 38 mm? 				
<ul style="list-style-type: none"> ▪ Do wall mounted grab bars have knuckle space 50 mm? 				
<ul style="list-style-type: none"> ▪ Are grab bar non slippery? 				
<ul style="list-style-type: none"> ▪ Can the grab bars withstand the load of 200kg minimum? 				
<ul style="list-style-type: none"> ▪ Are faucets easy to grip and operate with one hand? 				
<ul style="list-style-type: none"> ▪ Are shower fixtures with at least 1500 mm long hoses? 				
<ul style="list-style-type: none"> ▪ Are hot water pipes insulated or covered? 				
<ul style="list-style-type: none"> ▪ Is the toilet equipped with an emergency alarm system? 				
<ul style="list-style-type: none"> ▪ Can doors be locked from inside and releasable from outside under emergency situations? 				

<ul style="list-style-type: none"> ▪ Are flushing arrangements, dispensers and toilet paper mounted between 300mm and 800mm? 				
<ul style="list-style-type: none"> ▪ Are flushing equipments easy to operate? 				
<ul style="list-style-type: none"> ▪ Is the floor material skid proof, well drained and waterproof? 				
<ul style="list-style-type: none"> ▪ Do pivoted doors open outwards? 				

11. CANTEEN	YES	NO	NOT APPLICABLE	REMARKS
<ul style="list-style-type: none"> ▪ Is the eating outlet accessible for PwD's? 				
<ul style="list-style-type: none"> ▪ Is there a circulation path of at least 900 mm wide to allow a wheelchair user to move around the eating outlet? 				
<ul style="list-style-type: none"> ▪ Are the cash and service counter height below 800mm? 				
<ul style="list-style-type: none"> ▪ Is the table accessible with a height of 750mm to 850mm and knee space of 750mm wide and 480mm deep? 				
<ul style="list-style-type: none"> ▪ Do the table with fixed stools have accessible spaces for wheelchairs? 				

12. DRINKING WATER	YES	NO	NOT APPLICABLE	REMARKS
<ul style="list-style-type: none"> ▪ Is the Water tap accessible? 				
<ul style="list-style-type: none"> ▪ Can it be easily manoeuvred by a person with poor hand function? 				
<ul style="list-style-type: none"> ▪ Is the area dry? 				
<ul style="list-style-type: none"> ▪ Are glasses provided? 				

13. SIGNAGES	YES	NO	NOT APPLICABLE	REMARKS
<ul style="list-style-type: none"> ▪ Are accessible spaces identified by the international symbol of accessibility? 				
<ul style="list-style-type: none"> ▪ Are there directional signs indicating the location of accessible facilities? 				
<ul style="list-style-type: none"> ▪ Are maps, information panels and wall-mounted signs placed at a height between 900mm and 1800mm? 				
<ul style="list-style-type: none"> ▪ Are signs clear, simple and easy to read? 				
<ul style="list-style-type: none"> ▪ Is the colour of signs clearly distinguishable? 				
<ul style="list-style-type: none"> ▪ Is the surface of the sign processed so as to prevent glare? 				
<ul style="list-style-type: none"> ▪ Is the sign supplement by a text in embossed letters or in Braille available next to information signs? 				
<ul style="list-style-type: none"> ▪ Is the lettering size proportional to the reading distance? 				

14. EMERGENCY EXITS	YES	NO	NOT APPLICABLE	REMARKS
<ul style="list-style-type: none"> ▪ Are emergency exits clearly marked with directional arrow signs? 				

15. PUBLIC TELEPHONES	YES	NO		REMARKS
<ul style="list-style-type: none"> ▪ Are there public telephones accessible to wheel chair users? 				
<ul style="list-style-type: none"> ▪ Is there at least one telephone in the building equipped with a loop induction unit? 				
<ul style="list-style-type: none"> ▪ Are the numerals on the telephone raised to allow identification by touch? 				
<ul style="list-style-type: none"> ▪ Is there proper signage directing to the public telephone? 				
<ul style="list-style-type: none"> ▪ Are the heights of the operable parts of the telephone between 800mm and 1m? 				
<ul style="list-style-type: none"> ▪ Is there a clear knee space of 750mm? 				

16. RESTING FACILITIES	YES	NO		REMARKS
<ul style="list-style-type: none"> ▪ Where there are large spaces, are resting facilities provided at 30 meters of intervals? 				
<ul style="list-style-type: none"> ▪ Is there an adjoining space for a wheelchair next to benches and public seats? 				
<ul style="list-style-type: none"> ▪ Are public seats with height of 450-480mm? 				
<ul style="list-style-type: none"> ▪ Are knee spaces at accessible tables with a height of 750mm and knee space of 750mm wide and 480mm deep? 				

INTERNATIONAL PRACTICES IN BARRIER FREE STANDARDS

International best practices were compared with the guidelines to give a ready reference for design standards applicable across the world. This ensures that any revision or review of standards can be effected with ease.

S. No		Topic	Barrier Free Guidelines by MoUD	Disability Discrimination Act, European Union	Barrier Free Guidelines Toronto, Canada	Barrier Free Guidelines USA
1	Reach	Forward Reach	1200 mm High	1000 mm (comfortable) 1100mm (extended)	Not Specified	1220 mm High
			380 mm Low	650 mm (comfortable) 650mm (extended)	Not Specified	380 mm Low
		Side Reach	1300 mm Max	1060mm (comfortable) 1160mm (extended)	1370 mm	1370 mm High
			250 mm Low	665 mm (comfortable) 630mm (extended)	460 mm	230 mm Low
		Forward Reach with obstruction	1000 mm High with 500 max arm stretch	Not Specified	Not Specified	1220 mm
			1100 mm High with 600 max arm stretch	Not Specified	1220 mm	1170 mm
		2	Space Allowance	Clear floor space for one wheelchair	1000w x 1200d	1000mm clear min. width
Clear space for passing two wheelchairs	1800			2000 mm	Not Specified	1525 mm
For Rotating one wheel chair	1500 x 2000			1500 x 1500	Not Specified	1525 x 1525
For right angle turning the corridor	Not Specified			1200 x 1200	Not Specified	1525 x 1525

S. No		Topic	Barrier Free Guidelines by MoUD	Disability Discrimination Act, European Union	Barrier Free Guidelines Toronto, Canada	Barrier Free Guidelines USA
		180 degree turn	Not Specified	1600 x 2000	Not Specified	Not Specified
3	Controls	Doors handles, lift buttons, Handrails switches, etc	Shall not be higher than 1000 mm	Height of all the controls shall not be less than 50mm and not be more than 1200mm above ground level.	Shall not be higher than 1200 mm	Not Specified
			Shall be placed between 900-1000		Shall be provided at 915 mm	Not Specified
			Power points shall be between 600-1100 from finished floor level.		Not Specified	Not Specified
4	Levels & Ramps	Maximum Gradient	1:12	1:12	1:12	1:12
		Min. Width	900mm	2000 mm	1670 mm	915
		Maximum length of ramp in one go	9 Meter	2 Meter	9 Meter	9 Meter
		Height of Handrail	between 760-900mm	between 550 - 1100mm	Not Specified	between 865 - 965mm
		Minimum Gap between Handrail and wall	50 mm	50-60 mm	40 mm	38 mm
		Diameter of Handrail	38-45 mm	40 - 50 mm	30 - 50 mm	32 - 38 mm
		Minimum Clear Openings	900 mm	900 mm	915 mm	815 mm
5	Entrance & Exit Doors	threshold level difference	not more than 12 mm	Not Specified	Not Specified	not more than 19mm
		Height of Door Handle from Floor lvl	850 mm - 1100 mm	900 mm	915 mm -1065 mm	Not higher than 1220 mm.

S. No		Topic	Barrier Free Guidelines by MoUD	Disability Discrimination Act, European Union	Barrier Free Guidelines Toronto, Canada	Barrier Free Guidelines USA
		Door Handle Length	100 mm	120 mm	Not Specified	Not Specified
		Diameter of Door Handle	Not Specified	30-35 mm	Not Specified	Not Specified
		Clearance of door handle from door	Not Specified	45 mm	Not Specified	Not Specified
		Door Closer	Not Specified	Automatic	Not Specified	Sweep period of closer with a closing time of 3 second
6	Parking	Car	Not specified	Not Specified	Not Specified	For 2 Accessible Vans
		Parking Bay	2400 mm wide	Not Specified	3600 mm	2440 mm wide
		Unloading Platform	1200 mm	Not Specified	1500	1525 mm
7	Lifts	No. of Lifts	One Lift is provided	Not Specified	Not Specified	Not Specified
		Clear Internal Dimensions	1500 mm X 1500 mm	1400 mm X 2000 mm	1725 mm X 2286 mm	Not Specified
		Entrance Door Widths	900 mm	900 mm	915 mm	Not Specified
		Lift control heights	800-1000 mm High	1100 mm	Not Specified	Not Specified
8	Toilet	Size of Toilet	2200 X 2000 mm	2200 X 1500 mm	1500 X 1675 mm	2134 X 1575 mm
		Flooring Material	Non Slip Surface without level difference	Matt or Mid-sheen finishes are recommended	Not Specified	Not Specified
		Door Shutter	Light Weight door shutter	Not Specified	Not Specified	Push and pull type door not more than 22.2 N weight. Grab

S. No		Topic	Barrier Free Guidelines by MoUD	Disability Discrimination Act, European Union	Barrier Free Guidelines Toronto, Canada	Barrier Free Guidelines USA
						bars are not mounted above 1219 mm.
		Door Shutter Opening	900 mm	925 mm	810 mm	813 mm
		Grab Bars	40 mm dia vertical grab bar up to 700-800	38 mm dia vertical grab bar up to 1280 high	Vertical Grab bar L type Height is not Specified	Horizontal Grab bars 1321 mm width along WC
		WC Height	450-480 mm	480 mm	430 mm -460 mm	356-483 mm
		Wash Basin Height	Not specified	720-740 mm	Not Specified	686 mm
		Urinal Height	430	Rim height shall be 380mm from floor lvl	Not Specified	Not Specified
		Faucets	Not Specified	Not Specified	Automatic Type	Self closing faucet valves
		Signage	Braille Signage at 1400 mm along with illuminated symbol for disabled at 1500 mm	Not Specified	Not Specified	Not Specified
9	Signages	Height of Letters	Depends on Viewing distance (2m. To 50m) ranges from 6 mm - 150 mm	Depends on Viewing distance (1 % of distance at which the message read) Minimum shall be 22 mm	Depends on Viewing distance Minimum shall be 25 mm along with Braille lettering below	Depends on Viewing distance Minimum shall be 75 mm
		Height for Notices/ signs for wheelchair users	750 mm	Not Specified	Not Specified	Not Specified
		Height for	1200 mm	1400 mm with	Between 1370	Not Specified

S. No		Topic	Barrier Free Guidelines by MoUD	Disability Discrimination Act, European Union	Barrier Free Guidelines Toronto, Canada	Barrier Free Guidelines USA
		door, safety or other notices for ambulant users		bottom edge not less than 900 mm	mm - 1525 mm	
		Minimum Clearance for suspended or projected signs	2000 mm	2300 mm	Not Specified	2030 mm

BIBLIOGRAPHY

Anjlee, A. (2012). *Accessibility Research and comparative analysis of Building Standards & Regulations*. VSO & DFID.

Arth Astha & VSO. (2014). *Understanding the UNCRPD*. New Delhi: Arth Astha and VSO.

Indian Roads Congress. (2012). *IRC 103: 2012, Guidelines for Pedestrian Facilities*.

IRC. (2012). *IRC 103: 2012 Guidelines for Pedestrian Facilities*. New Delhi: IRC.

National Disability Authority. (1998). *Buildings for Everyone*. National Rehabilitation Board.

Ron Mace. (n.d.).

http://www.ncsu.edu/www/ncsu/design/sod5/cud/about_ud/about_ud.htm. Retrieved 2014, from www.ncsu.edu:

http://www.ncsu.edu/www/ncsu/design/sod5/cud/about_ud/about_ud.htm

Samarthyam. (2009). *AgarwalAnjlee and SachdevaSanjeev, 2008, Guidelines for Training of Trainers for Promotion of Universal Design*. Rehabilitation Council of India.

UNCRPD. (2008). <http://www.icrpd.net/implementation/en/index.htm>. Retrieved 2014, from www.icrpd.net: <http://www.icrpd.net/implementation/en/index.htm>

Bureau of Indian Standards, National Building Code, 2005

Manual on Barrier Free Environment, O/o the Chief Commissioner for Persons with Disabilities, 2002

Guidelines and Space Standards for Barrier Free Built Environment for Disabled and Elderly Persons, 1998, CPWD

GLOSSARY

Access Aisle- An accessible pedestrian space between elements, such as parking spaces, seating and desks that provides clearances appropriate for use of the elements.

Accessible- A site, building, facility, or portion thereof that complies with these Guidelines and that can be approached, entered and used by all people.

Accessible Route- A continuous unobstructed path connecting all accessible elements and spaces in a building or facility that can be negotiated by a severely disabled person using a wheelchair and that is also safe for and usable by people with other disabilities. Exterior accessible routes may include parking, access aisles, curb ramps, walkways and ramps. Interior accessible routes may include corridors, ramps, elevators, lifts, and clear floor space at fixtures.

Accessible Signage- Any visual way finding system incorporates architecture, landscape design, lighting, landmarks and orientation points. Signage is one key element of an effective way finding system and should be accessible to all users including people with disabilities.

Ambulatory Disabled- A person who is able, either with or without personal assistance, and who may depend on prostheses (artificial limbs), orthotics (calipers), sticks, crutches or walking aids to walk on level or negotiate suitably graded steps provided that convenient handrails are available.

Automatic Door- A door equipped with a power operated mechanism and controls that open and close the door automatically upon receipt of a momentary signal. The switch that begins the automatic cycle may be photoelectrical device, floor mat, sensing device, or manual switch mounted on or near the door itself.

Beveled- Smooth, slanted angle between two surfaces; for example, a slant or inclination between two uneven surfaces to allow easier passage of a wheelchair.

Braille Signage(Ron Apelt, John Crawford and Dennis Hogan, 2007)- Is a specialist way finding device that incorporates Braille as a primary source of information for people who are vision impaired and maybe aided with raised tactile lettering, maps or pictorial images.

Braille- The Braille system is a method that is widely used by blind people to read and write.

Circulation Path-An exterior or interior way of passage from one place to another for pedestrians, including walkways, hallways, courtyards, stairways and stair landings.

Clear - Unobstructed

Colour Contrast- The basic guidelines for making effective colour choices are based on the hue value of the colours. The most commonly used methods of achieving colour contrast incorporate either 'harmonising' or 'contrasting' colour combinations.

Cross Slope- Cross slope or camber is a geometric feature of pavement surfaces: the transverse slope with respect to the horizon. It is a very important safety factor. Cross slope is provided to provide a drainage gradient so that water will run off the surface to a drainage system such as a street gutter or ditch.

Disability- is an umbrella term for impairments (WHO, 2004), activity limitations, and participation restrictions, denoting the negative aspects of the interaction between an individual (with a health condition) and that individual's contextual factors (environmental and personal factors). Disability is neither simply a biological nor a social phenomenon but arises from the relationship between health condition and context.

Grab Bars- A bar used to give a steadying or stabilizing assistance to a person engaged in a particular function.

Handrails- A rail used in circulation areas such as corridors, passageways, ramps and stairways to assist in continuous movement.

Hue - Hue is the perceptual attribute associated with elementary colour names. Hue enables us to identify basic colour categories such as blue, green, yellow, red and purple. People with normal colour vision report that hues follow a natural sequence based on their similarity to one another. With most colour deficits, the ability to discriminate between colours on the basis of hue is diminished.

Individual Washrooms-A compartment having the basic requirements of a water closet compartment, washbasin and other essential washroom accessories as required by people with disabilities.

Induction loop - An induction or inductive loop is an electromagnetic communication or detection system which uses a moving magnet to induce an electric current in a nearby wire. Induction loops are used for transmission and reception of communication signals, or for detection of metal objects in metal detectors or vehicle presence indicators. A common modern use for induction loops is to provide hearing assistance to hearing-aid users.

International Symbol of Access- Also known as the (International) Wheelchair Symbol, the International Symbol of Access consists square overlaid with a stylized image of a person using a wheelchair. The symbol is often seen where access has been improved, particularly for wheelchair users and other mobility impaired persons. The symbol denotes a barrier free environmental, such as steps, to help

also older people, parents with prams, and travellers with luggage. The wheelchair symbol is "International" and therefore not accompanied by Braille in any particular language. Specific uses of the ISA include:

Kerb - A side barrier to a trafficable surface or is the edge where a raised sidewalk/footpath, road median, or road shoulder meets an unraised street or other roadway.

Kerb Ramp- A short ramp cutting through a curb or built up to it or a Kerb is a drop, with walk way, at a gradient no greater than 1:10 on both sides of necessary and convenient crossing points (figure 2 & 5). Width should not be less than 1200mm. If width (X) is less than 1200mm, then slope of the flared side shall not exceed 1:12.

Knurled Surface- Roughened area, often in a crisscross pattern; used on either doorknobs or grab bars. On doorknobs, it is used to provide tactile clues to visually impaired persons to indicate that passage leads to an area of danger. On grab bars it is used to improve grasp and to prevent slipping.

LRV- Light reflectance value (LRV) is the total quantity of visible light reflected by a surface at all wavelengths and directions when illuminated by a light source.

Luminosity Contrast- Also known as tonal contrast is the most important element that assists people with vision impairments to distinguish between two different surfaces. A minimum difference of 26 points in the Light Reflectance Value of colours of two architectural surfaces produces an adequate luminosity contrast that is perceivable by persons with vision impairments.

- Marking a parking space reserved for vehicles used by Persons with Disabilities
- Marking a public lavatory with facilities designed for wheelchair users

Lux - Is the standard unit of illumination. It is used as a measure of perceived intensity of light.

Operable Parts- A part of a piece of equipment or appliance used to insert or withdraw objects, or to activate, deactivate, or adjust the equipment or appliance (for example coin slot, pushbutton, handle).

Passing places- a space on footpath, single track road or one lane road that permits two ways travels when it is not wide enough to allow wheelchairs/vehicles to pass one another.

Persons with Disabilities¹- A Person with Disability is a person with any physical, mental, intellectual or sensory impairment which in interaction with various barriers may hinder full and effective participation in society on an equal basis with others. The term "Persons with Disabilities", consistent with the terminology used in the

¹ Rights of Persons with Disabilities Act, 2012; <http://www.disabilitystudiesnalsar.org/lawpolicy.php>

CRPD, is used throughout these Guidelines.

Public Areas - Interior and exterior rooms or spaces that are made available to the general public. Public use may be provided at a building or facility that is privately or publicly owned.

Public Use- Describes interior and exterior rooms or spaces that are made available to the general public. Public use may be provided at a building or facility that is privately or publicly owned.

Ramp- An inclined way connecting one level with another.

Signage- Any room number, name tag, building directory, or similar object containing a printed message and/or symbol. Signage and signs are used synonymously in this document.

Space- A definable area (for example, toilet room, hall, assembly area, entrance, storage, room alcove, courtyard, or lobby).

Table Top- road raised to footpath/footway level at crossing or with leveled.

Tactile(CRC, 2007)- Tactile means information and interpretations derived from the sense of touch. This involves sensory transfer through physical contact of the hands or feet with other surfaces, as well as sensory transfers received by contact with non-physical elements such as pressure, wind and temperature.

Tactile paving/tiles- (also called Tactile Ground Surface Indicators) provide a distinctive surface pattern of "strips" and "truncated domes" or cones (which are small domes or cones that have had their tops cut off, or truncated) detectable by long cane or underfoot which are used to guide/alert persons with vision impairments of their approach to facilities, streets and hazardous drop-offs. People who are blind or visually impaired are alerted of impending danger from vehicle impact or a grade change.

Tactile signs (Refer also to Braille Signage)-Tactile signage incorporates raised text or symbols to enable touch reading by people who are blind, and touch enhancement of visual perception for people who are vision impaired.

Tactile Guiding Blocks - These are 300 x 300 mm tiles that incorporate bars that are 5mm (\pm 0.5mm) high, 20mm wide and spaced 50mm from the centre of one bar to the centre of the next. These flat topped bars that are easily detectable underfoot by people with visual impairments. They are used externally to guide people with visual impairments along the circulation path. They may also be used internally in large busy areas such as railway stations and airports.

Tactile Warning Blocks - In order to warn persons with visual impairments of the approaching danger, it is recommended to incorporate Tactile Ground Surface

Indicators (TGSIs) along the approach path to unavoidable obstacles and hazards. TGSIs, also commonly known as 'Tactile Warning Blocks', are 300 mm x 300 mm tiles that incorporate rows of 5 mm (± 0.5 mm) high flat-topped blister like domes that are easily detectable underfoot by persons with visual impairments. These tactile warning blocks are recognized internationally as a sign of approaching hazards.

Traffic island- can be a median strip, a strip in the middle of a road. It can also be a narrow strip between roads that intersect at an acute angle. Some traffic islands may serve as refuge islands for pedestrians.

Universal Design- Defined as "the design of products and environments to be usable by all people, to the greatest extent possible, without the need for adaptation or specialized design".

Vision impairment- Vision impairment is any significant loss of sight.

Water Closet Compartment/Toilet Cubicle- A compartment having a water closet with grab bars installed to assist people with physical disabilities

Wheelchair User -A person who depends on a wheelchair for mobility

White Cane - A white cane is a long rod-like device used by blind or visually impaired travelers to give them information about the environment they are traveling through.